

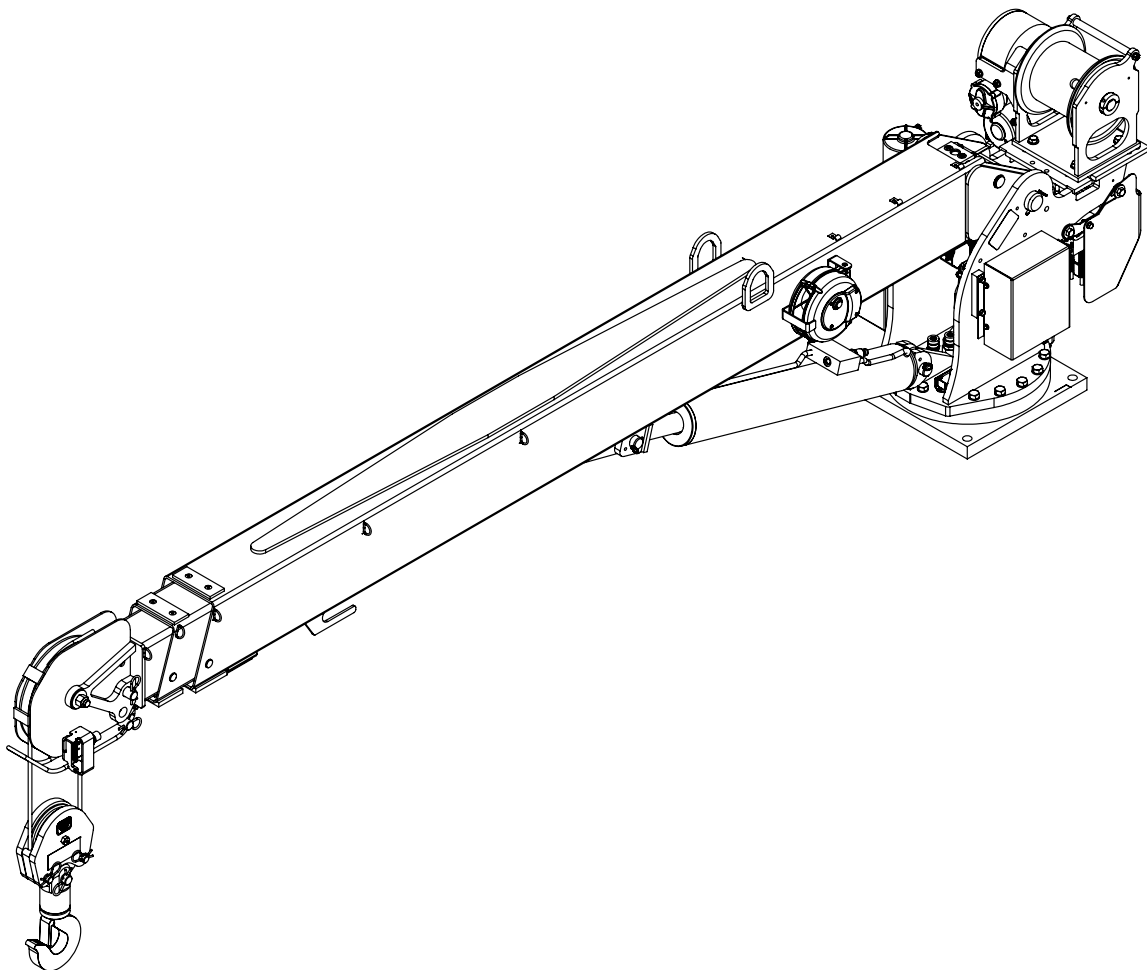

OWNER'S MANUAL

EHC-6 NEXSTAR



990800008-0226-D

Phone: 1-800-777-2760
Fax: (918) 269-6688

<http://www.autocrane.com>
actechsupport@autocrane.com

4707 N. Mingo Rd.
Tulsa, OK 74117-5904

Product Registration

Thank you for purchasing an Auto Crane® product and taking a few moments to register it online at <https://www.autocrane.com/product-registration/>. Your registration helps us keep you up to date on product information and gives you one of the strongest manufacturer's limited warranties available.

By completing the product registration, you may be eligible for valuable supplemental coverage under Auto Crane's Limited Warranty. For more information and a list of eligible products, visit our Warranty page found at <https://www.autocrane.com/warranty/>.

Before You Register

What do I need to get started?

We'll ask for:

- The product model and serial number for each product you purchased
- Your contact information so we can send confirmation of your registration and communicate product bulletins
- The date you purchased the product, date of installation or in-service (e.g. copy of bill of sale)
- Truck VIN (if applicable)
- The name, address and phone number of the dealer who sold and installed your equipment

NOTE: Much of this information will be on the invoice provided by your dealer. If you need help, please contact your installing dealer.

At the time of publishing this manual is accurate to the best of our knowledge. Auto Crane reserves the right to change any or all items, components and parts, necessary for any reason. This right does not obligate Auto Crane to immediately update the manual. Please call your local Auto Crane distributor for the most up-to-date information.

Auto Crane Company issues a limited warranty with each unit sold. See warranty pages at the end of the manual.

Table Of Contents

Product Registration	2
Table Of Contents.....	3
Safety Tips and Precautions	5
Introduction	6
General Specifications	7
Dimensions.....	7
Rating.....	7
Reach	7
Cable.....	7
Line Speed	7
Chassis and Mounting Requirements	7
Electrical System Requirements.....	7
Rotation	7
General Dimensions	8
Load Chart.....	9
Qualifications and Operating Practices	10
Operators.....	10
Qualifications For Operators	10
Conduct Of Operators.....	10
Operating Practices/Handling The Load	11
Operating Near Electrical Power Lines.....	12
Preparing The Crane For Operation	14
During Operation.....	15
After Operation	15
NexStar Operation.....	16
General.....	16
Remote Control Unit.....	16
Remote Control Initialization	16
Pre-Operation Test	16
Remote Control Layout.....	17
Display Screen Layout.....	18
Menu Screen Layout	19
Speed and Control Mode.....	20
Counterbalance Override Procedures	21
Control Valve Override Procedures	21
Tether Connection.....	22
Low Remote Battery.....	23
Auto Deploy.....	24
Auto Stow	25
Setting Home Position	27
Personnel Basket Mode.....	29
Remote Layout.....	31
NexStar Troubleshooting.....	33
NexStar Remote Troubleshooting Table	33
NexStar Error Code Table.....	35
Electrical Troubleshooting Table	38
Electrical Harness Schematic.....	40

Table Of Contents

Voltage Switching Unit Schematic	41
Hydraulic Troubleshooting Table.....	42
Hydraulic Schematic	43
Maintenance.....	44
Inspection Requirements	44
Inspection Classification	44
Frequent Inspection	44
Periodic Inspection.....	45
Cranes Not In Regular Use	46
Inspection Records	46
Testing Requirements.....	46
General Repairs and Maintenance	47
Maintenance Precautions	47
Adjustments and Repairs	47
Lubrication	47
Rope Replacement	48
Rope Installation and Maintenance.....	48
Paint Finish Maintenance	49
Lubrication and Maintenance Schedule	50
Lubrication Points	51
NexStar Control Valve Cartridge Maintenance	52
Rotation Bearing Replacement.....	53
Electric Hoist Maintenance and Operation.....	54
Rotation Gearbox/Slewing Drive Maintenance	54
Brake Adjustment.....	55
Eccentric Ring Adjustment	56
Installation	57
General Installation	57
General Electrical Hookup	59
Voltage Switching Unit Installation	60
Voltage Switching Unit	61
Docking Station	62
Stability Chart Installation	63
Large Crane Serial Number Location.....	65
Recommended Operating Temperature	66
Decal Layout - P/N 366800030	67
General Assembly - P/N 366664003	69
Pedestal Assembly - P/N 366664050	72
Hydraulic Valve Bank - P/N 366800205	80
Wiring Harness - P/N 360646075	82
Hoist Assembly - P/N 113001	83
Rotation Gearbox - P/N 160247	86
Boom Assembly - 480988101	88
Traveling Block Assembly - P/N 366066000.....	91
Warranty.....	92

Safety Tips and Precautions



Indicates a hazardous situation which, if not avoided, will result in death or serious injury.



Indicates a hazardous situation which, if not avoided, could result in death or serious injury.



Indicates a hazardous situation which, if not avoided, could result in minor or moderate injury.



Indicates information considered important, but not hazard-related.



Federal law (49 CFR part 571) requires that the Final Stage Manufacturer of a vehicle certify that the vehicle complies with all applicable federal regulations. Any modifications performed on the vehicle prior to the final state are also considered intermediate stage manufacturing and must be certified as to compliance. The installer of this crane and body is considered one of the manufacturers of the vehicle. As such a manufacturer, the installer is responsible for compliance with all applicable federal and state regulations and is required to certify that the vehicle is compliant.



It is the further responsibility of the installer to comply with the OSHA Truck Crane Stability Requirements as specified by 29 CFR part 1910.180 (C) (1). In applications, where the rotation of the load is hazardous, a tag or restraint line should be used, (ref. OSHA 1910.180(h)(3)(xvi)). To reduce the potential for the load to rotate or rope twist, operate at minimal boom angles and extension.



This crane is designed for vertical lifts only. Do not attempt to lift or drag a load from the side! The boom can fail far below its rated capacity.



Do not weld, modify, or use unauthorized components on any Auto Crane unit as failure of the crane may occur. This will void any warranty or liability.



Failure to correctly plumb and wire crane can cause inadvertent operation and damage to crane and/or personnel!



Auto Crane Company remote controlled cranes are not designed or intended for use for any applications involving the lifting or moving of personnel when not using authorized Auto Crane Company personnel attachments. Any such unauthorized use is considered to be improper and the seller shall not be responsible for any claims arising from such use. There is no implied warranty or responsibility for such uses.

Introduction

NOTICE

Keep this manual with the crane at all times.

Auto Crane products are designed to provide many years of safe, trouble-free, dependable service when properly used and maintained.

To assist you in obtaining the best service from your crane and to avoid untimely crane and/or vehicle failure, this manual provides proper operating and service instructions. It is specifically recommended that all operating and service personnel consider this manual as mandatory material for reading and study before operating or servicing Auto Crane products. It is highly recommended that crane owners, equipment managers, and supervisors also read this manual.

In addition, the overall dimensions, rotation, and turning radius of the crane are included on the General Dimension Drawing.

Remember, the crane adds weight to the vehicle which may change the driving and riding characteristics of the vehicle unless the appropriate overload spring(s) are installed. The payload of the vehicle is reduced by the weight of the crane. The operator should exercise care when loading the vehicle. Distributing the payload on the vehicle evenly will greatly improve the driving and riding characteristics of the vehicle.

The cranes are electrically powered by a 12-volt DC electrical system. The use of a maintenance-free battery is not recommended on any Auto Crane product. The recommended alternator and battery that will give the longest life with the most useful duty cycle is a 60-amp alternator with a 500 cold cranking amp battery. These specifications should be considered minimum.

It has always been Auto Crane Company policy to handle all warranty claims we receive as promptly as possible. If a warranty claim involves discrepant material or workmanship, Auto Crane will take immediate corrective action. It is understandable that Auto Crane Company cannot assume responsibility of liability when it is obvious that our products have been abused, misused, overloaded or otherwise damaged by inexperienced persons trying to operate the equipment without reading the manual.

Auto Crane will not assume responsibility or liability for any modifications or changes made to the unit, or installation of component parts without authorization.

Auto Crane maintains a strong distributor network and a knowledgeable Customer Service Department. In most cases, an equipment problem is solved via phone conversation with our customer service department. This department also has the ability to bring in a local distributor, regional sales manager, or factory serviceman to help determine the solution to an equipment problem.

Auto Crane Company's extensive Research and Development Program allow our customers to use the best equipment on the market. Our engineering staff and knowledgeable salespeople are always available to our customers in solving crane and service body application problems. When in doubt, call the Auto Crane factory.

Should you require any assistance not given in this manual, we recommend that you consult your nearest Auto Crane Distributor. Our distributors sell authorized parts and have service departments that can solve almost any needed repair. This manual does not cover all maintenance, operating, or repair instructions pertinent to all possible situations.

If you require additional information, please contact the Auto Crane Company at the following telephone number: 1-800-777-2760

General Specifications

Dimensions

- Width: 22.375 in. (0.57 m)
- Height: 35.75 in. (0.91 m)
- Length: 12 ft 11.875 in. (3.99 m), stored length.
- Weight: 1,770 lb (667 kg)

Rating

- Crane Capacity: 6,000 lb
 - Double Line: 6,000 lb maximum
 - Single Line: 3,000 lbs maximum
- 36,000 ft-lb (3.81 ton-m)
- Ft-lb = horizontal distance from center line of rotation to free hanging weight (feet) x amount of weight (pounds).

Reach

- Second boom reach: 10 ft. 6 in. to 16 ft. 6 in.
- Third boom reach: 16 ft. 6 in. to 20 ft. 6 in.

Cable

- 95 ft. (28.9 m) of 3/8 in. (9.5 mm) diameter aircraft quality cable. This cable has a single line breaking strength of 14,400 lb (6,531 kg).

Line Speed

- 36 ft. per minute (no load, single line)

Chassis and Mounting Requirements

- 14,500 lb (6,577 kg) GVWR minimum
- 360,000 in-lb Resistive Bending Moment (RBM)
- 7/8", Grade 8-UNF Bolts. Tightened to 501 ft-lb
- 9" Mounting hole to run electrical lines to the crane from the body

Electrical System Requirements

- Voltage: 12 VDC
- Alternator: 165 amps minimum
- Battery: 100 minute reserve capacity minimum. Maintenance Type battery

Rotation

- 450° range

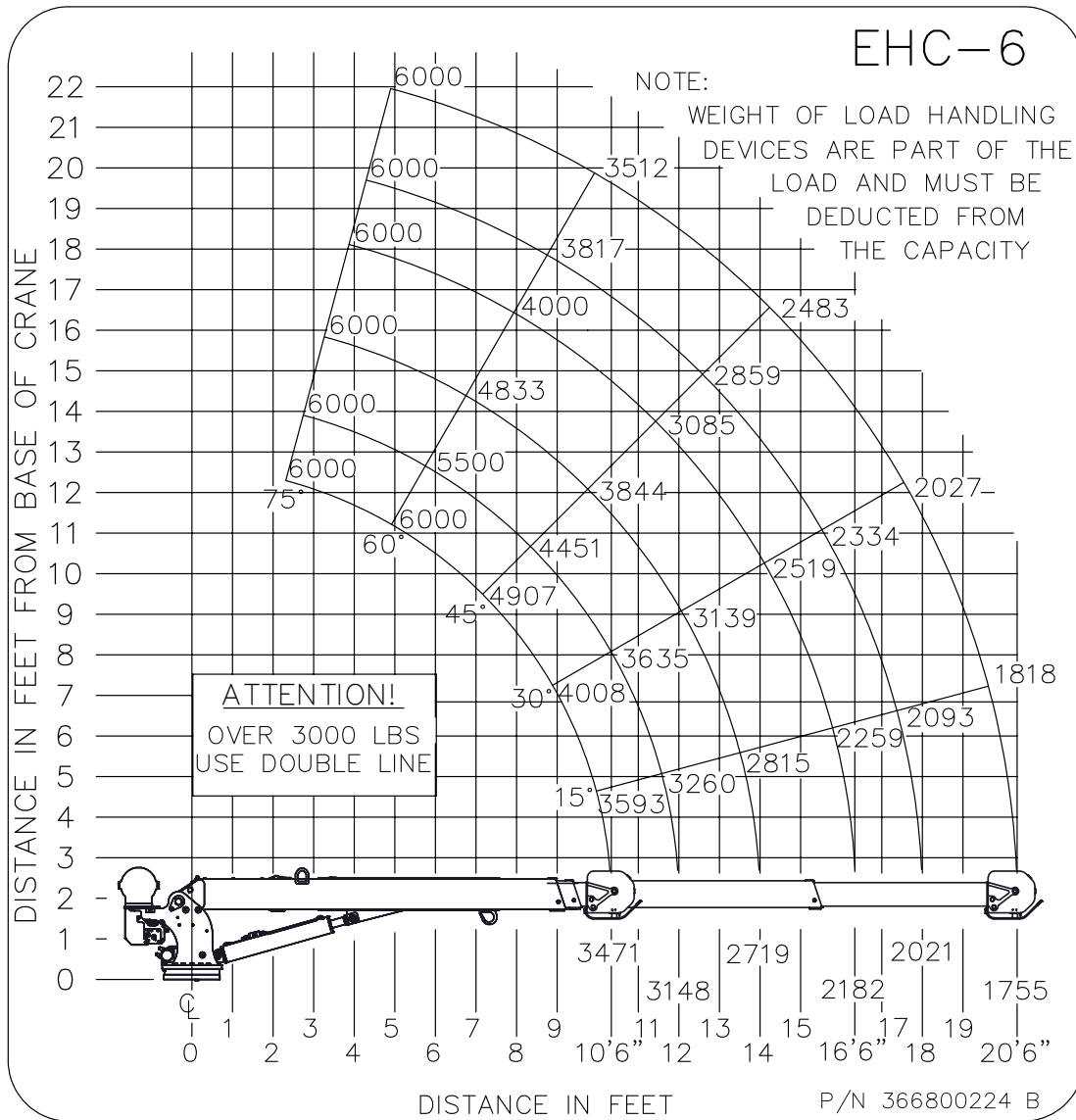

WARNING

All load ratings are based on crane capacity, not vehicle stability. When lifting a heavy load, the weight can create enough tipping moment to overturn the vehicle. DO NOT USE the overload shutdown device to determine maximum rated loads.



WARNING

Always comply with load chart capacities. Weight of load handling devices (i.e. traveling block, hook, clevis, etc.) are part of the load and must be deducted from the crane capacity.

Qualifications and Operating Practices

THIS IS ONLY AN OVERVIEW OF ALL APPLICABLE QUALIFICATION REQUIREMENTS. REFERENCE ASME B30.5 AND OSHA 1910.180 FOR COMPLETE QUALIFICATION REQUIREMENTS.

Operators

1. Crane operation shall be limited to personnel with the following minimum qualifications:
 - A. Designated persons.
 - B. Trainees under the direct supervision of a designated person.
 - C. Maintenance and test personnel (when it is necessary in the performance of their duties).
 - D. Inspectors (crane).
2. No one other than the personnel specified above shall enter the operating area of a crane with the exception of persons such as oilers, supervisors, and those specified persons authorized by supervisors whose duties require them to do so, and then only in the performance of their duties and with the knowledge of the operator or other persons.

Qualifications For Operators

1. Operators shall be required by the employer to pass a practical operating examination.
2. Qualifications shall be limited to the specific type of equipment for which examined.
3. Operators and operator trainees shall meet the following physical qualifications:
 - A. Vision of at least 20/30 Snellen in one eye and 20/50 in the other, with or without corrective lenses.
 - B. Ability to distinguish colors, regardless of position, if color differentiation is required for operation.
 - C. Adequate hearing with or without hearing aid for the specific operation.
4. Evidence of physical defects or emotional instability, which render a hazard to operator or others, which in the opinion of the examiner could interfere with the operator's performance, may be sufficient cause for disqualification. In such cases, specialized clinical or medical judgment and tests may be required.
5. Evidence that operator is subject to seizures or loss of physical control shall be sufficient reason for disqualification. Specialized medical tests may be required to determine these conditions.
6. Operators and operator trainees should have normal depth perception, coordination, and no tendencies towards dizziness or similar undesirable characteristics.
7. In addition to the above listed requirements, the operator shall:
 - A. Demonstrate the ability to comprehend and interpret all labels, operator's manuals, safety codes, and other information pertinent to correct crane operation.
 - B. Possess the knowledge of emergency procedures and be able to implement them.
 - C. Demonstrate to the employer the ability to operate the specific type of equipment.
 - D. Be familiar with the applicable safety regulations.
 - E. Understand the operating procedures as outlined by the Auto Crane.
 - F. Be thoroughly familiar with the crane and its control functions.

Conduct Of Operators

1. The operator shall not engage in any practice which will divert his attention while operating the crane.
2. Each operator shall be responsible for those operations under the operator's direct control. Whenever there is any doubt related to safety, the operator shall consult with the supervisor before handling the loads.
3. The operator should not leave a suspended load unattended unless specific precautions have been instituted and are in place.
4. If there is a warning sign on the switch or engine starting controls, the operator shall not close the switch or start the engine until the warning sign has been removed by the appointed person.

Qualifications and Operating Practices

5. Before closing the switch or starting the engine, the operator shall see that all controls are in the "OFF" or neutral position and all personnel are in the clear.
6. If power fails during operation, the operator shall:
 - A. Move power controls to the "OFF" or neutral position.
 - B. Land the suspended load and boom, if practical.
7. The operator shall be familiar with the equipment and its proper care. If adjustments or repairs are necessary, the operator shall report the same promptly to the appointed person and shall also notify the next operator.
8. At the start of each shift, the operator shall test all controls. If any controls do not operate properly, they shall be adjusted or repaired before operations are begun.
9. Stabilizers shall be visible to the operator while extending or setting unless a signal person assists operator.

Operating Practices/Handling The Load



Never use two cranes to support a load too large for either crane.

1. Size of load.
 - A. No crane shall be loaded beyond the rated load except for test purposes.
 - B. The load to be lifted is to be within the rated load of the crane and its existing configuration.
 - C. Know the weight of the rigging and deduct from the load rating to prevent overloading the crane.
 - D. When loads that are not accurately known are to be lifted, the person responsible for the job shall determine the weight of the load does not exceed the crane rated load at the radius at which the load is to be lifted.
2. Attaching the load.
 - A. Ensure the load is properly attached to the hook by means of slings or other devices of sufficient capacity.
 - B. Ensure the vehicle is in a level position when loading or unloading.
 - C. Hoist rope shall not be wrapped around the load.
3. The operator shall determine that:
 - A. The crane is level and, where necessary, the vehicle/carrier is blocked properly.
 - B. The load is well secured and balanced in the sling or lifting device before it is lifted more than a few inches.
 - C. Means are provided to hold the vehicle stationary while operating the crane.
 - D. Before starting to lift, the hook shall be positioned over the load in such a manner as to minimize swinging.
4. During lifting care shall be taken that:
 - A. There is no sudden acceleration or deceleration of the moving load.
 - B. When rotating the crane, sudden starts and stops shall be avoided. Rotational speed shall be such that the load does not swing out beyond the radius at which it can be controlled.
 - C. Load, boom or other parts of the crane do not contact any obstruction.
 - D. Cranes shall not be used for dragging loads sideways.
 - E. ASME B30.5 recognizes that mobile and locomotive cranes are designed and intended for handling materials and not generally personnel. However, personnel are permitted to ride in an Auto Crane authorized, boom-mounted, personnel platform when used in accordance with the requirements of ASME B30.23 and Auto Crane's instructions. The crane shall not be used for other purposes while handling personnel (Refer to ASME B30.23). Hook attached suspended work platforms (baskets) shall not be used with Auto Crane cranes.
 - F. The operator should avoid carrying loads over people.

Qualifications and Operating Practices

5. When the crane is so equipped, the stabilizers shall be fully extended and set. Blocking under stabilizers shall meet the requirements as follows:
 - A. Sufficient strength to prevent crushing, bending, or shear failure.
 - B. Of such thickness, width and length as to completely support the stabilizer pad.
 - C. Firm footing under all tires, or individual stabilizer pads should be level. Where such a footing is not otherwise supplied, timbers, cribbing, or other structural members to distribute the load so as to not exceed allowable bearing capacity or the underlying material should provide it.
6. In transit, the boom shall be carried in stowed position.
7. The crane shall not be transported with a load on the hook.

Operating Near Electrical Power Lines



Never operate the crane near electrical lines or in the danger zone area.

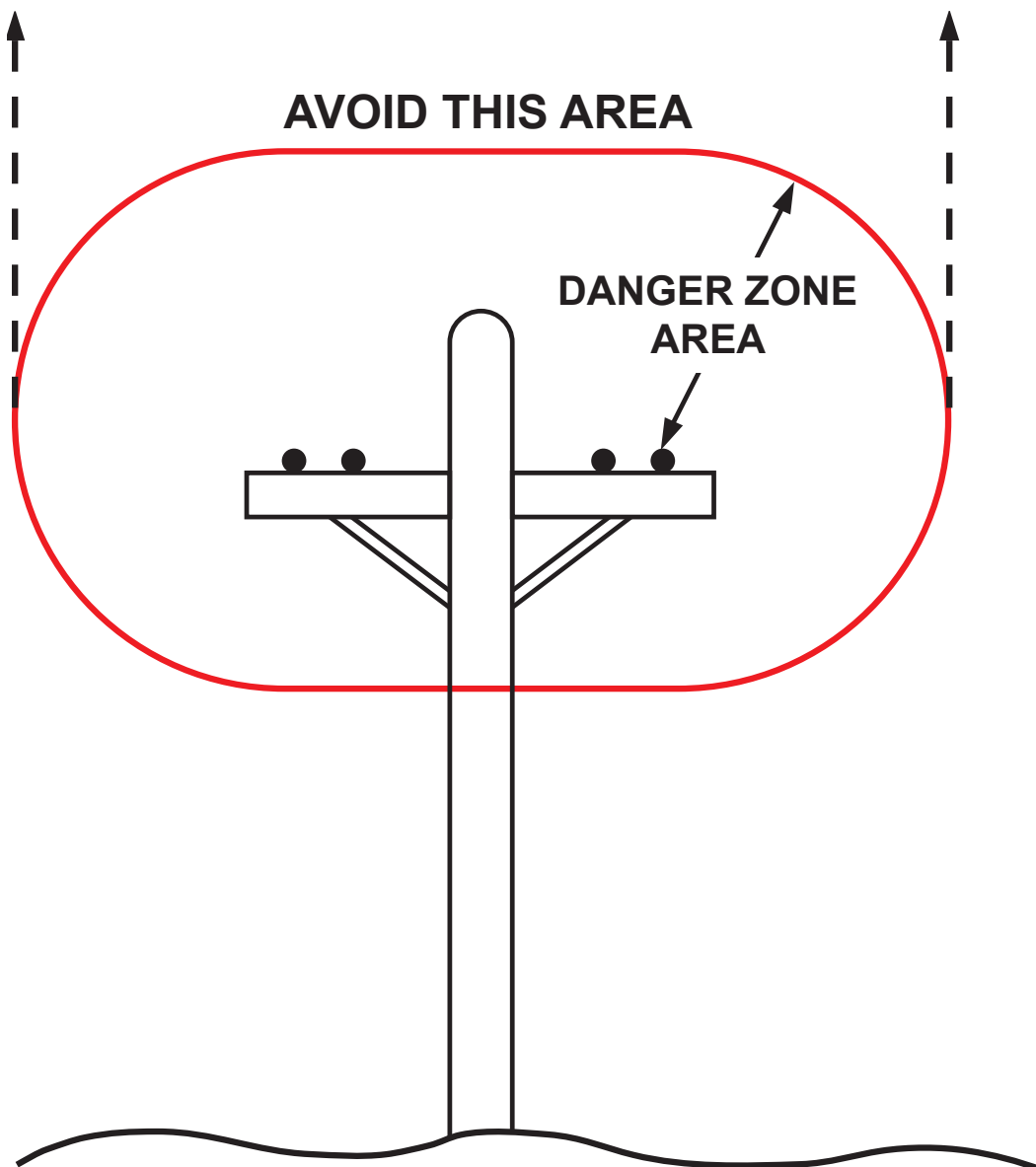

Qualifications and Operating Practices

1. Do not place any part of the crane or load inside the Danger Zone.

Exceptions:

- A. The Danger Zone may be entered after confirmation by an appointed person that electrical distribution and transmission lines are de-energized and visibly grounded at the point of work.
 - B. The Danger Zone may be entered if insulating barriers are erected to prevent physical contact with the lines. These can't be a part of or attached to the crane.
2. For the minimum safe distance between electrical lines and any part of the crane or load (including handling appendages), or while in the transit with the boom stowed, see Safe Operating Distance Table below.
 3. Exercise caution when working near overhead lines. They can move horizontally and vertically due to wind, shifting the location of the Danger Zone.
 4. Assign a qualified, signal person to observe the clearance and warn the crane operator before approaching the Safe Operating Distance limits.
 - A. Treat all overhead wires as energized until the person or utility owning the line verifies it is not energized.
 - B. Exceptions ensuring equivalent protection are allowed, if approved by the administrative or regulatory authority in writing.
 - C. Install durable signs at the operator's station and on the outside of the crane, warning that electrocution or serious bodily injury may occur if the Safe Operating Distance Table limits are not adhered to.

Safe Operating Distance for Cranes Near Electrical Lines	
Normal Voltage, kv (Phase to Phase)	Specified Clearance, ft (m)
During Operation	
Up to 50	10 (3)
Over 50 to 200	15 (4.6)
Over 200 to 350	20 (6.1)
Over 350 to 500	25 (7.6)
Over 500 to 750	35 (10.7)
Over 750 to 1,000	45 (13.7)
Over 1,000	Determine specific clearance after consultation with utility owner/operator
During Transit or Travel With No Load and Boom or Mast Lowered	
Up to 0.75	4 (1.2)
Over 0.75 to 50	6 (1.8)
Over 50 to 345	10 (3.1)
Over 345 to 750	16 (4.9)

Qualifications and Operating Practices

Preparing The Crane For Operation

1. Ensure the manual has been thoroughly read by all crane operating and maintenance personnel, and supervisors.
2. Perform a routine inspection of the crane before operation each day, correcting any defects immediately.
3. At the job site, position the vehicle so the crane can reach the load within the rated capacity (center line of rotation to hoist hook).
4. Keep the vehicle as level as possible during operation.

NOTICE

At a 10% slope, all crane functions are limited to 50% speed. At a 15% slope, all crane functions are disabled.

5. Allow the vehicle engine to warm up before operation.
6. For Auto Crane units using only electric operation:
 - A. Engage the emergency brake.
 - B. Leave the ignition on with the transmission in park (or neutral for manual transmissions).
 - C. Activate any crane power switches.
7. For Auto Crane units using electric and hydraulic operation:
 - A. Engage the emergency brake.
 - B. Place the transmission in park (automatic trans.) or neutral (manual trans.).
 - C. Activate PTO (Power Take Off).
 - D. Allow sufficient time for the hydraulic fluid to warm up.
 - E. Set the throttle control to the proper engine speed.
8. For all outrigger usage:
 - A. Always extend the outriggers from the vehicle to the ground before crane operation.
 - B. Ensure they are firmly positioned on solid ground.
 - C. Stand clear of outriggers while being extended.
 - D. If a curb or other object prevents the outrigger from being fully extended, shorten the bearing or fulcrum point and reduce the maximum load accordingly.
 - E. If an outrigger will not reach the ground because of holes or grades, block up the outrigger pad to provide level and firm support to the vehicle.
 - F. If working in soft ground, use wide pads under the outrigger feet to prevent sinking.
 - G. Always store the outriggers before transportation.
 - i. For Auto Crane units with Manual Outriggers:
 1. Pull the lock pins to release the jackleg or drop down outrigger. Move to the outermost lock position.
 2. Ensure lock pins are reinstalled properly.
 3. Lower the Outrigger pad to firm ground and adjust the foot to remove slack.
 - ii. For Auto Crane units with Hydraulic Outriggers:
 1. Shift the diverter valve to the Outrigger position.
 2. Extend the Outriggers to their horizontal limit.
 3. Extend the Outriggers vertically until they make solid contact with the ground and the truck is approximately level side-to-side.
9. With the Outriggers properly positioned, return the diverter valve to the "Crane" position.
10. Remove the remote control from the cab or storage area. Power the remote control on. Detach the hook from the hook stow.
11. The crane is now ready for operation.

Qualifications and Operating Practices

During Operation

1. Always boom up before rotating so the boom will clear the boom support.
2. Always maintain clearance between the boom crown and the traveling block or hook hoist during boom extension.
3. Always observe all relevant safety policies and procedures during crane operation.
4. Always use slow and smooth movements with the crane to avoid causing the load to swing like a pendulum.

After Operation

1. After completing the lifting operations, return the boom to the stowed position on the boom support.
2. Replace remote control to its storage location.
3. Return the Outriggers to the stowed position (ensure they are pinned in place or jack legs are returned to the storage compartment).
4. Always store the crane in its stowed position for transportation.
5. Release the throttle control.
6. Press the clutch in (manual trans.).
7. Disengage the PTO.
8. Deactivate any crane power switches.
9. Check vehicle surroundings before moving.
10. Record any unusual occurrence(s) during crane operation which may indicate required maintenance or repair.

NexStar Operation

This section describes the general operation for cranes with the NEXSTAR control system.



Before operating the remote control, read and understand all safety information in this manual, any manual supplements, and any applicable local, state, or federal rules and regulations.



Never drive with a load suspended from the crane.



Ensure personnel and objects are clear of the crane path during operation. Do not move loads over personnel.

General

Radio controlled equipment operates in several directions. Frequently there are other pieces of equipment and personnel in close proximity. The operator must exercise extreme caution at all times.

Only properly trained operators should operate the radio controlled equipment. This includes knowing and following all applicable operating and maintenance manuals, safety procedures, regulatory requirements, and industry standards and codes.

Remote Control Unit

Never mechanically block the switches ON or OFF. When not in use, turn the remote control OFF. Always store the remote control in a secure space when not in use. Store spare remote controls in a secure space and only remove after the current remote control has been turned OFF, taken out of the service area, and secured. Before disposing of batteries, consult local and governmental regulatory requirements for instructions on proper disposal.

Remote Control Initialization

After powering on the remote control, the LCD display screen turns on and will perform a self-test. During the self-test, the NexStar remote control scans for any switches, buttons, triggers that are in the OFF position. If any switches, buttons, or triggers are on, the "E002 ACTIVITY" failure displays on the display screen and the remote control powers down.

After a successful self-test, the NexStar remote control will enter the Normal Operating Mode.

Pre-Operation Test

Before operating the crane, or when a new operator takes control of the equipment, operators should perform the following checks of the equipment before making a lift:

- Test all warning devices.
- Test all functions.
- Test the remote control E-Stop function.

Remote Control Layout

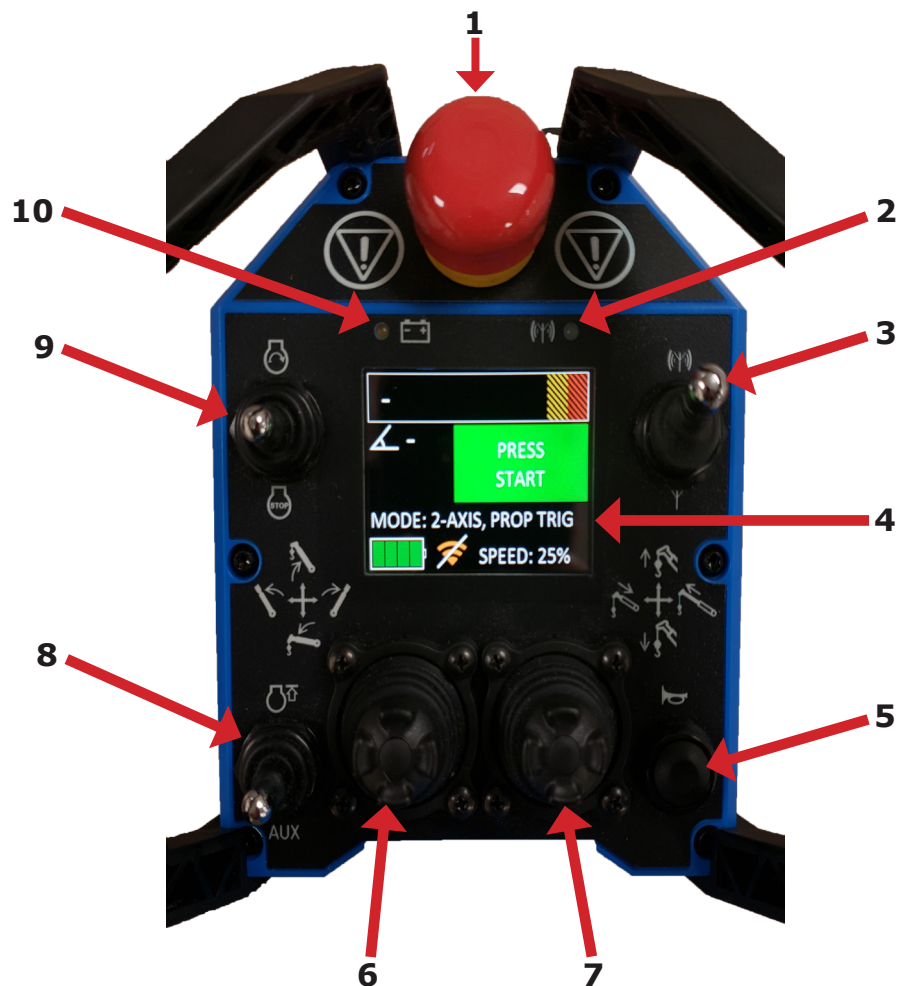

1. **Emergency Stop** - Push to activate, pull to release, then cycle remote power to reset. When activated, E-Stop stops all outputs from receiver.
2. **Link LED** - Off during normal operation. Solid yellow if offline, slow flash if remote battery is low.
3. **On/Off Switch** - Turns remote on and off. Pull locking lever out prior to lever up (On) or down (Off).
4. **Display Screen** - LED screen that displays many crane operating parameters, codes, and functions.
5. **Horn/Start Button** - Used to activate horn once remote is linked, used to link remote to receiver.
6. **Right Joystick** - Press the joystick up to raise the hook. Press the joystick down to lower the hook. Press the joystick right to extend the boom. Press the joystick left to retract the boom.
7. **Left Joystick** - Press the joystick up to raise the boom. Press the joystick down to lower the boom. Press the joystick right to rotate the crane clockwise. Press the joystick left to rotate the crane counterclockwise.
8. **High Idle/Aux Switch** - Press the switch up to activate vehicle high idle. Press the switch up once more to deactivate vehicle high idle. Press the switch down to activate an optional feature (air compressor, etc.). Press the switch down once again to deactivate the optional feature.
9. **Engine Start/Engine Stop Switch** - Press the switch up to start the vehicle engine. Press the switch down to turn off the vehicle engine.
10. **Battery LED** - Solid green if online, slow flash if remote battery is low.

NexStar Operation

Display Screen Layout



1. **Load Ribbon** - Displays current crane load as a percentage of total capacity. Ribbon will be green between 0% and 90% capacity. The value displayed when the crane is unloaded may be higher than 0% due to the weight of the boom.
2. **90% Load** - Between 90% and 100% load ribbon will display yellow indicating crane is nearing full capacity.
3. **100% Load** - Will display red if load meets or exceeds 100% of crane capacity.
4. **Info-Box** - Will display green with text upon start-up. Once the Horn/Start button has been pressed and remote is linked with receiver, it will display green with no text. Any alarms or warnings will be displayed here. Box will be red with no text if there is no link between the remote and receiver.
5. **Speed Setting** - Displays current maximum crane operation speed setting.
6. **Transmitter Icon** - Will have line through if no link is present. Will display cord if remote is tethered.
7. **Battery Level** - Will display remaining transmitter battery in increments of 25%.
8. **Joystick Mode** - Displays current control configuration selected.
9. **High Idle/Aux** - Displays respective icon if High Idle and/or Aux has been activated.
10. **Boom Angle** - Displays the current boom angle in degrees.

Menu Screen Layout

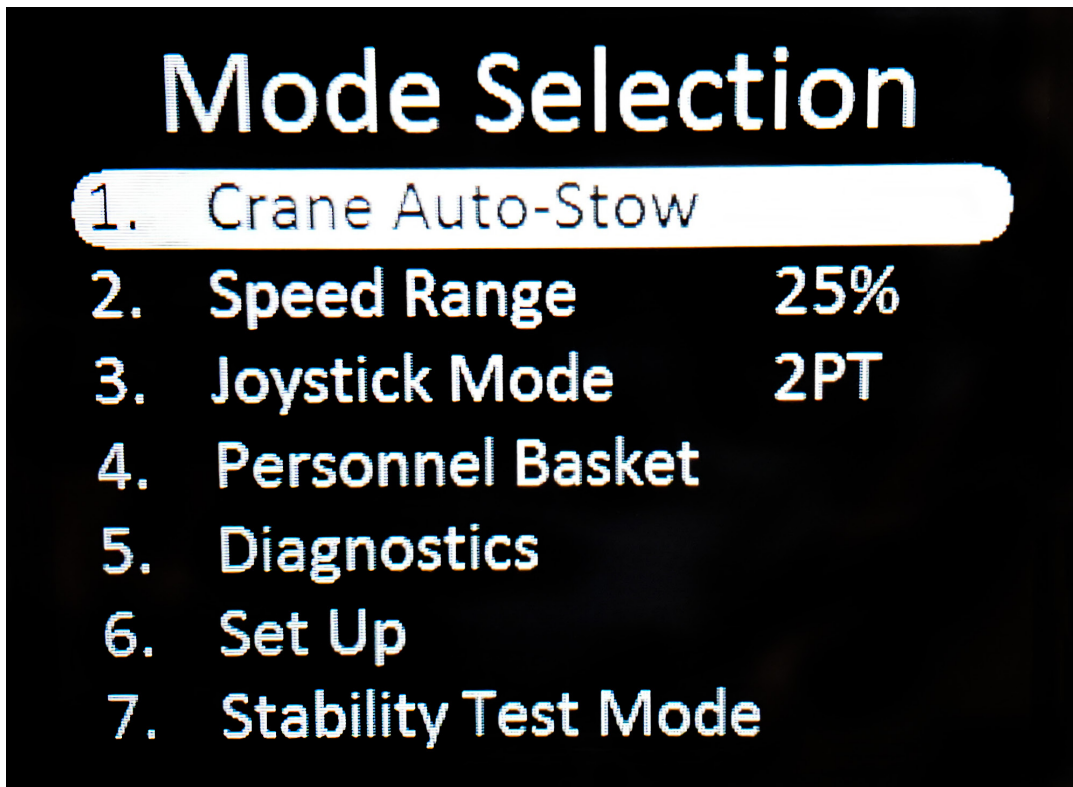

To enter the menu screen, first fully depress and hold the trigger, then press the Engine Start/Stop switch down to Engine Stop and then release the trigger. The screen above will be displayed. The left joystick is used to navigate through the menu. To enter into the Diagnostics and Set Up sub menus, highlight them and depress the trigger. To back out of the menu(s), Engine Start/Stop switch down to Engine Stop (unless directed otherwise via on-screen instructions).

1. **Crane Auto-Stow** – Automatically stows the crane back to home position. Reference Auto Stow section in NexStar Operation.
2. **Maximum Speed Setting** - Displays the current maximum speed setting.
3. **Joystick Mode** - Displays the current mode selected.
4. **Personnel Basket** – For use when Auto Crane Personnel Basket is attached to crane. Reference Personnel Basket Mode section in NexStar Operation.
5. **Diagnostics** - Displays four options (Active Alarms, Joystick Inputs, Switch Inputs, and Outputs) to help aid in troubleshooting.
6. **Set Up** - Displays two usable options: Adjust Brightness of screen and Adjust Sleep Timer for remote auto shut-off. "Set Home Position" is part of the Crane Auto Stow program. Reference Auto Stow section in NexStar Operation.
7. **Stability Test Mode** – For dealer use only.

NexStar Operation

Speed and Control Mode



Speed Selection

Highlight "Speed Range" in the menu screen with the Left Joystick. Depress the trigger to cycle through the maximum speed settings of 25%, 50%, 75%, and 100%. Once the desired speed is displayed, back out of the menu using by pressing the Engine Start/Stop switch down to Engine Stop.

Mode Selection

Highlight "Joystick Range" in the menu screen with the Left Joystick. Depress the trigger to cycle through the joystick mode settings of 1PT, 2PT, 1PJ, and 2PJ. Once the desired mode is displayed, back out of the menu using by pressing the Engine Start/Stop switch down to Engine Stop.

Mode Selection

In 1-AXIS operation, once the joystick is moved in the direction of the desired function, the other functions are locked out until the joystick returns to the center position. For example, if you are booming up, you cannot rotate at the same time. But one function of the other joystick will be available to use.

In 2-AXIS operation, each joystick can perform two functions simultaneously.

1-AXIS, TRIGGER PROP (1PT) – Allows only one function to operate on each joystick. The joysticks are on-off and only need to be moved in the direction of the desired function. The speed control is located in the trigger. The more the trigger is pulled, the faster the function will operate.

2-AXIS, TRIGGER PROP (2PT) – Allows two functions to operator on each joystick. The joysticks are on-off and only need to be moved in the direction of the desired function. The speed control is located in the trigger. The more the trigger is pulled, the faster the function will operate.

1-AXIS, TRIGGER EN (1PJ) – Allows only one function to operate on each joystick. The speed is controlled by the joystick. The more the joystick is moved in the direction of the desired function, the faster the function will operate.

2-AXIS, TRIGGER EN (2PJ) – Allows two functions to operate on each joystick. The speed is controlled by the joystick. The more the joystick is moved in the direction of the desired function, the faster the function will operate.

Counterbalance Override Procedures

If, in an emergency situation, it becomes necessary to lower the boom without hydraulic flow available, the counterbalance valve located on the lift cylinder can be used to carefully perform this action.

1. Ensure the boom will lower onto a proper support.
2. Loosen the lock nut and slowly turn adjustment screw clockwise until the boom begins to slowly lower, counting the number of turns it takes to begin seeing movement.
3. Remove hand/arm/fingers from cranes while boom is lowering.
4. After boom is lowered, turn adjustment screw counter-clockwise the approximate number of turns made during lowering procedure and tighten lock nut.

NOTICE

Turning adjustment screw too far will cause valve to come apart on the inside. This condition is not repairable, and the counterbalance valve must be replaced.

WARNING

Do not try to adjust any valves while boom is moving. Doing so may result in personal injury!

Control Valve Override Procedures

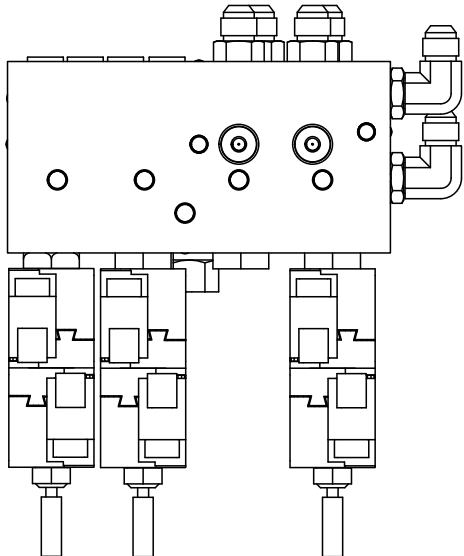

The diagram shows a control valve assembly with three override buttons. Each button is connected to a hydraulic line. The buttons are labeled as follows:

- BOOM EXT (PUSH)** and **BOOM RET (PULL)** with a vertical double-headed arrow.
- BOOM UP (PUSH)** and **BOOM DN (PULL)** with a vertical double-headed arrow.
- ROT CCW (PUSH)** and **ROT CW (PULL)** with a vertical double-headed arrow.

MANUAL OVERRIDE PROCEDURES

- 1) APPLY 24VDC FROM BATTERY TO PUMP POWER TERMINAL.
- 2) APPLY GROUND FROM BATTERY TO GROUNDING CONNECTION.
- 3) SELECT THE FUNCTION DESIRED, THEN CLOSE THE GAP BETWEEN COLLAR AND THE END ON THE OVERRIDE BUTTON.
- 4) PUSH OR PULL THE OVERRIDE BUTTON FOR THE DESIRED DIRECTION OF MOVEMENT. THE FARTHER THE BUTTON IS DEPRESSED OR PULLED, THE FASTER THE FUNCTION WILL OPERATE.

366800208 REV C

NexStar Operation

Tether Connection

If a tether connection is wanted (or necessary), connect one end of the cable that is supplied (Part Number: 366823427) to the crane tether connection (located in either the crane box, or on the crane itself), and the other to the tether connection located on the top of the remote.

If the tether connection is properly established, a cable icon will replace the transmitter icon on the main screen.

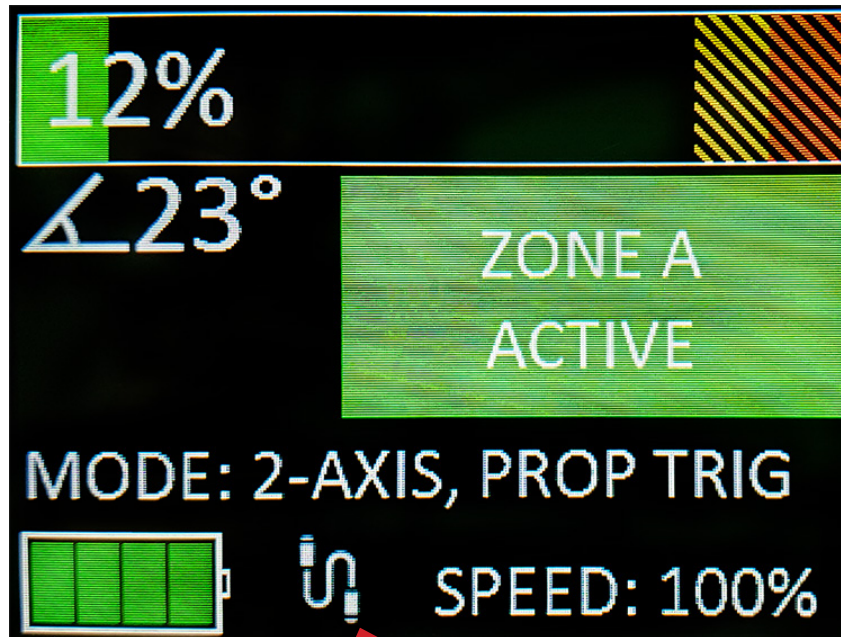

NOTICE

FM radio transmission/reception is disabled when remote is tethered to crane.

Low Remote Battery

The NexStar remote uses a rechargeable, internal lithium-ion battery which is usually charged when the remote is placed in the docking station that is powered by +12 VDC. In the event that the remote battery has been sufficiently drained, the remote can be recharged by placing it in the docking station, tethering it to the crane, or using the auxiliary battery pack.

To use the auxiliary battery pack, first install 3 AA alkaline batteries into their respective places, paying attention to how they should be oriented in the pack. The battery pack can then be slid into place.



CAUTION

Use only alkaline batteries, size AA in the auxiliary battery pack.

NOTICE

If the remote battery has been discharged to the point that the remote turns off, it may be necessary to allow the remote to charge (docking station, tether, or battery pack) for a time before wireless use can continue.

NOTICE

If immediate use of a discharged remote is needed, it is recommended to use the tether connection. This will allow for both use of the transmitter as well as charging the remote battery.

NexStar Operation

Auto Deploy

Auto Deploy allows the operator to move the boom from the home position (usually the cradle) to a predefined position without having to manually move the boom. From the starting position, the boom will elevate to a preset angle, rotate to the deployed position, raise to the final angle, then pay out hoist cable, releasing the hoist block from the stow hook.

The boom present angles, rotation position, and speeds are all preset in the controller.



Check that the path from the home position to the deployed position is clear of any obstructions, otherwise, equipment damage and/or personal injury could result.



When deployed, the hoist block will swing outwards.



Auto Deploy will not initiate if the boom is not in the home position.

To initiate Auto Deploy, ensure that the crane is on and operational (power, hydraulics, etc.), fully depress and hold the trigger, then press the Engine Start/Stop switch up to Engine Start. This should begin boom motion and the boom will move towards the deployed position. When the boom has reached its final position, it will cease movement.

To pause the Auto Stow process, release the trigger. To resume motion, depress and hold the trigger. If the operator attempts any manual boom control during Auto Stow, the sequence will be cancelled, and the initial conditions will need to be met again.



Keep constant watch on the crane as it moves through the cycle. If the crane needs to stop during automatic movements, release the trigger.

Auto Stow

Auto Stow allows the operator to move the boom to the home position (usually the cradle) without having to manually move the boom. From the starting position, the boom will elevate to a preset angle, swing over to the home position, and lower down into the final position, a predefined angle above the home position. Once in this position, the operator can fine-tune the boom position in the cradle if needed.

NOTICE

The boom preset angle and speeds are all preset in the controller. Once initiated, the operator only must hold the trigger to enable boom motion.

Prior to using Auto Stow, the following initial conditions must be met:

- 1. The boom is fully retracted.
- 2. The hoist block is properly stowed on load hook.
- 3. The boom is lowered to an elevation below the home position.

WARNING

Retracting the boom and stowing the hoist block must be done by the operator prior to initiating Auto Stow. There is no means of detecting these conditions prior to initiating boom motion. If Auto Stow is used without retracting the boom and stowing the hoist block, equipment damage and/or personal injury could result.

NOTICE

Auto Stow will not initiate if the boom is above the home elevation.

To initiate Auto Stow, first fully depress and hold the trigger, then press the Engine Start/Stop switch down to Engine Stop and then release the trigger. Auto Stow will be the default menu selection.



NexStar Operation

Release the trigger, then depress and hold the trigger again to select Auto Stow. The display will return to the main screen and will display "AUTO STOW ACTIVE" in a blue Info-Box. If "AUTO STOW ACTIVE" does not display, try releasing the trigger, the depressing and holding it again. If Auto Stow still does not initiate, check to ensure the initial conditions are met.

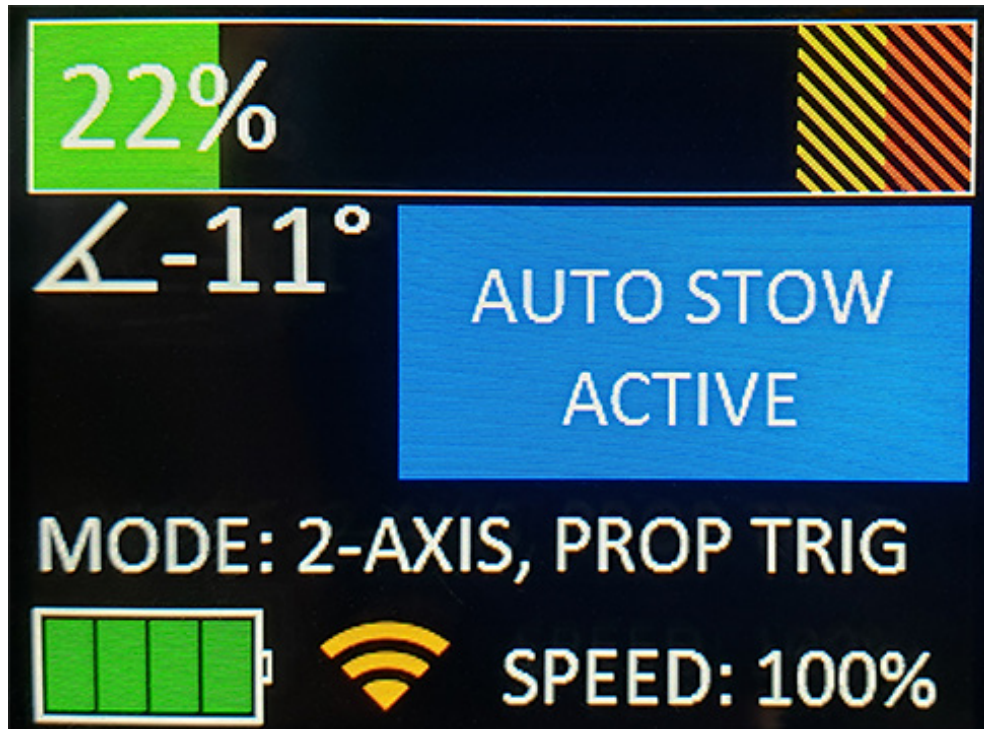

Once Auto Stow is initiated, the boom will move towards the home position. When the boom is in its final position, the main screen will display a green Info-Box and the boom will stop moving.

If the boom was rotated a full turn clockwise and is past the home position when Auto Stow is initiated, the boom will rotate the full turn, counterclockwise, to unwrap the cable/hoses running up through the base.

NOTICE

To pause the Auto Stow process, release the trigger. To resume motion, depress and hold the trigger. If the operator attempts any manual boom control during Auto Stow, the sequence will be cancelled, and the initial conditions will need to be met again.

CAUTION

Keep constant watch on the crane as it moves through the cycle. If the crane needs to be stopped during automatic movements, release the trigger.

Setting Home Position

To set home position:

1. Position the boom at the desired home position (usually the cradle).
2. Enter the menu screen by fully depressing and holding the trigger, then pressing the Engine Start/Stop switch down to Engine Stop and then release trigger.
3. Use the left joystick to navigate down to "Set Up" and depress the trigger.

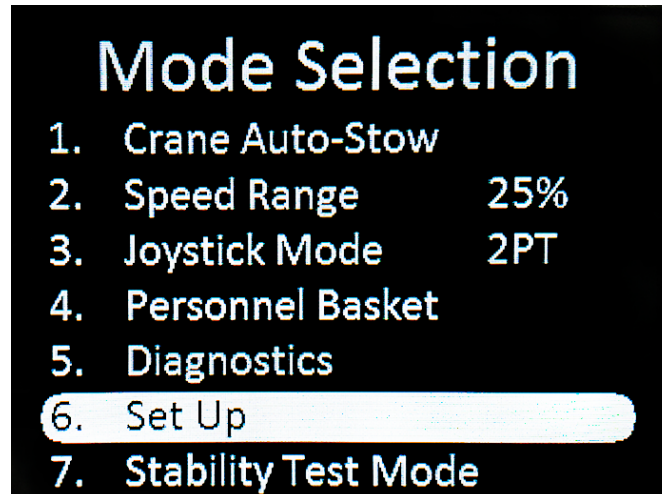

4. On the Set Up screen, select "Set Home Position".



NexStar Operation

5. Carefully read the Caution note on the screen, and if the conditions are met, select "CONFIRM" and depress the trigger.



This will set the current rotation position to zero and save the current boom angle as the home position.

Personnel Basket Mode

Personnel Basket Mode is used when an Auto Crane Personnel Basket is attached to the crane. When Personnel Basket Mode is activated the following occurs:

1. Boom speeds are reduced by 50%.
2. Hoist up/down function is deactivated.

To initiate Personnel Basket Mode:

1. Ensure that the crane is on and operational (power, hydraulics, etc.), and that the personnel basket has been deployed and attached to the crane per Auto Crane instructions.
2. Fully depress and hold the trigger, then press the Engine Start/Stop switch down to Engine Stop and then release the trigger to bring up the Mode Selection Screen.
3. Use the left joystick to navigate down to "Personnel Basket."
4. Depress trigger to initiate Personnel Basket Mode.

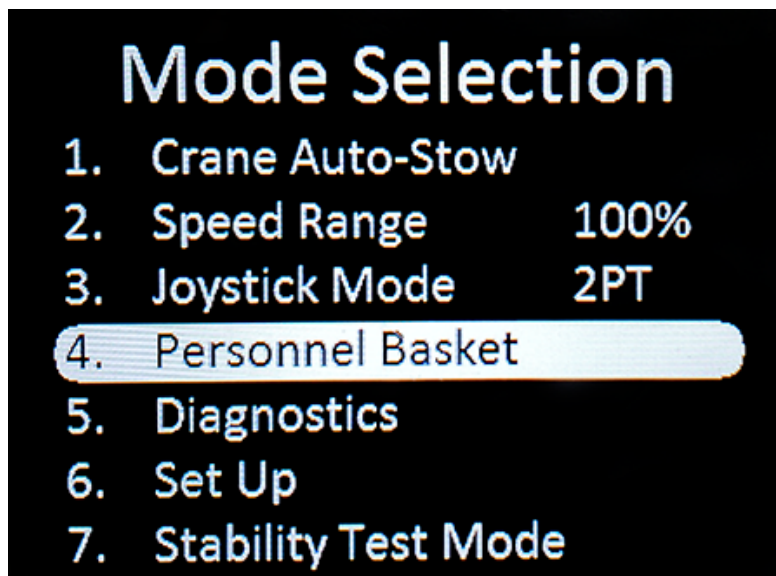

NexStar Operation

The remote will display "Personnel Basket Active."

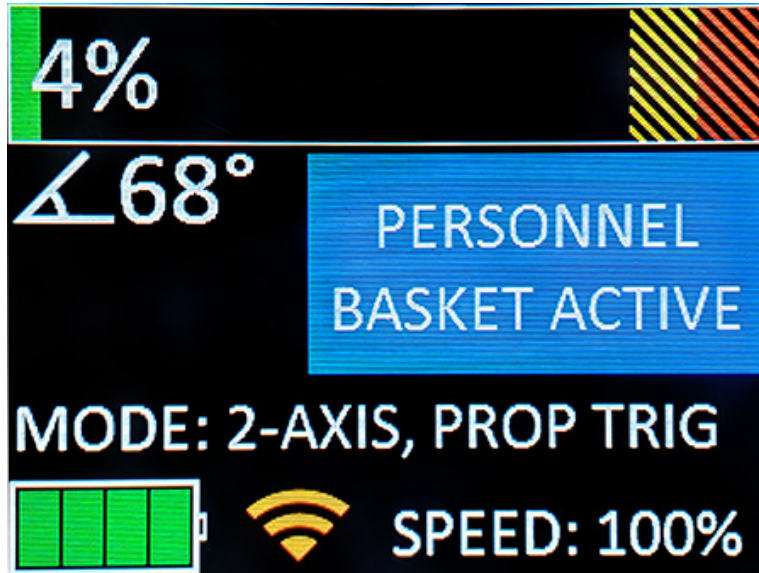













To end Personnel Basket Mode:

1. Cycle electrical power to the crane.
2. Cycle remote power.

NOTICE

While in Personnel Basket Mode, remote can be turned off without disengaging Personnel Basket Mode. Only cycling crane power will end Personnel Basket Mode.



Remote Layout

DIRECTION	FUNCTION	GRAPHIC	DESCRIPTION
Up	Engine Start		Sends a 12 VDC+ signal to start vehicle
Down	Engine Stop		Sends a 12 VDC+ signal to stop vehicle
Up	Boom Up		Moving the joystick up activates boom up function
Down	Boom Down		Moving the joystick down activates boom down function
Left	Rotate CCW		Moving the joystick to the left activates counterclockwise rotation function
Right	Rotate CW		Moving the joystick to the right activates clockwise rotation function
Up	Hoist Up		Moving the joystick up activates hoist up function
Down	Hoist Down		Moving the joystick down activates hoist down function
Left	Boom Retract		Moving the joystick to the left activates boom retract function
Right	Boom Extend		Moving the joystick to the right activates boom extend function
Up	Auxiliary	AUX	Sends a signal that activates an auxiliary output to operate an external component
Down	High Idle		Sends a signal that activates High Idle on the vehicle
Up	On		Turns remote on*
Down	Off		Turns remote off

* Although the power switch maybe in the "On" position, it does not necessarily mean that there is communication between the remote and the crane. The remote goes to sleep after a certain amount of time. If the remote goes to sleep, it can be "woken up" by depressing the trigger, or moving either joystick in any direction.

NexStar Operation

Remote Layout

DIRECTION	FUNCTION	GRAPHIC	DESCRIPTION
In	Emergency Stop Activated		Activates Emergency Stop
Out	Emergency Stop Deactivated		Deactivated Emergency Stop
In	Horn/Link		Momentarily activates an audible signal and red light

NexStar Remote Troubleshooting Table

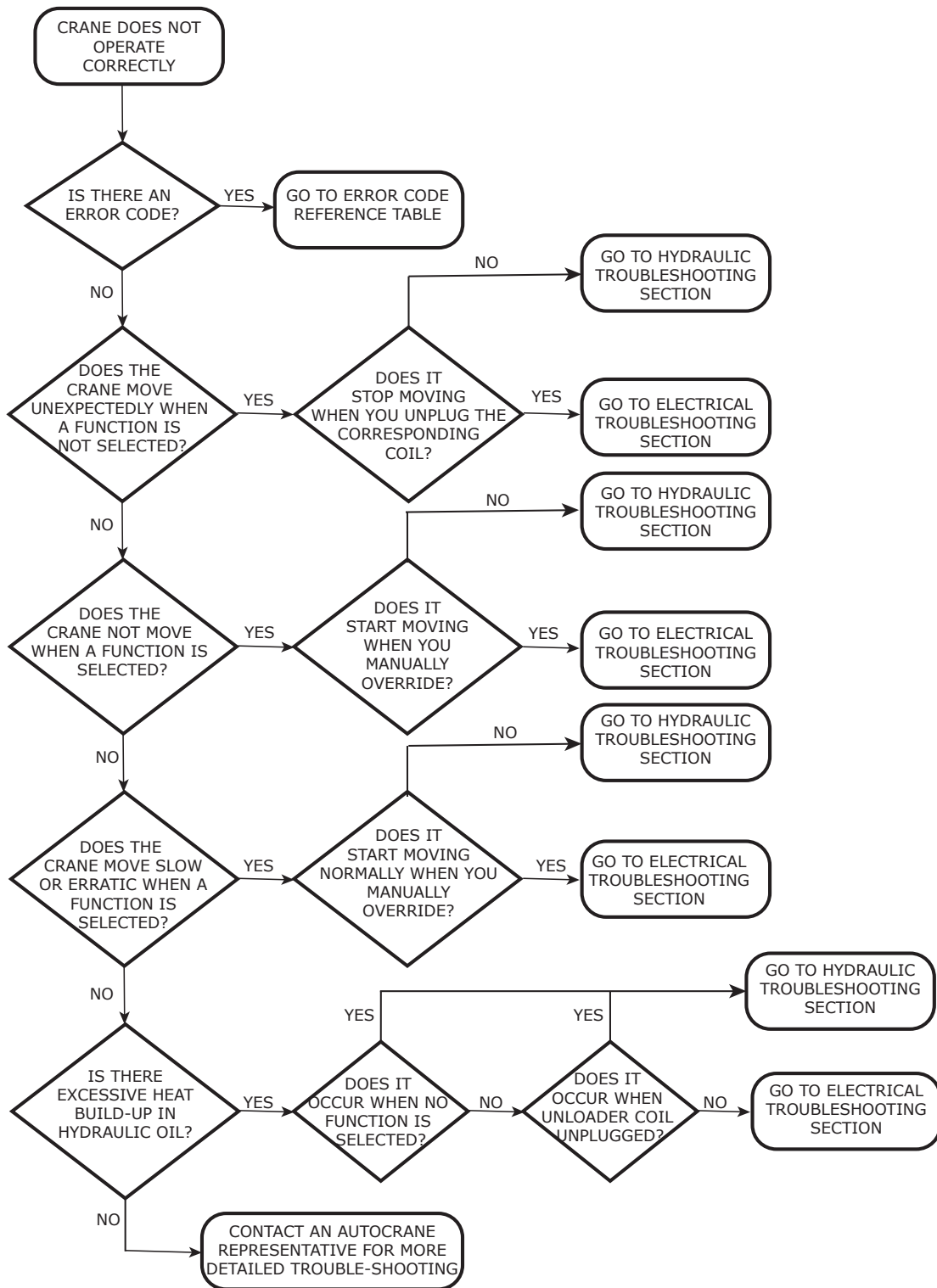

NexStar Troubleshooting

NexStar Remote Troubleshooting Table

PROBLEM	POSSIBLE REASON	ACTION
Remote control will not turn on	Remote control Emergency Stop switch is engaged.	Ensure the Emergency Stop switch is pulled out.
	Internal battery has discharged below operating level.	Attach backup alkaline battery pack or tether cable. Allow time for internal battery to charge (approx. 15 minutes) then cycle power.
Remote control will not communicate with the base station	Incorrect system RF channel.	Ensure the remote control and the base station are set to the same RF channel by synching the remote to the base station.
	System out of range.	Ensure the startup procedure is initiated within 100 feet of the receiver. Ensure the signal strength indicator level is greater than one bar.
Remote control will not respond with base station when tethered	System not in tether mode.	Ensure the remote is started up and initiated with the tether cable attached.
	The tether cable or connectors are damaged	Inspect the tether cable and/or connectors for damage.
Remote control will not turn on in tether mode.	Remote control Emergency Stop switch is engaged.	Ensure the Emergency Stop switch is pulled.
	The connecting tether cable is not installed, installed improperly, or is damaged.	Ensure the tether cable is installed and secured correctly. Inspect the tether cable and connectors for damage.
	Remote control is failing switch scan.	Ensure all switches, buttons, and joysticks are in the off position.
Remote control will not communicate with the base station in wireless mode	System not in wireless mode.	Ensure that the startup procedure is initiated within 100 feet from the base station. Ensure the signal strength indicator is greater than one bar.

NexStar Error Code Table

INFO BOX	CAUSE	EFFECT	SOLUTION
BOOM PSI LOW	Boom pressure is below 80 PSI	Disables all functions except boom up and hoist down.	Hoist down (if applicable) and raise boom off any supports. Alarm will clear once pressure in cylinder is restored.
CW LIMIT	Crane has reached the limit of rotation in the clockwise direction	Disables clockwise rotation.	Rotate counter-clockwise to clear error. Once switch is deactivated the alarm will clear.
CCW LIMIT	Crane has reached the limit of rotation in the counter-clockwise direction	Disables counter-clockwise rotation.	Rotate clockwise to clear error. Once switch is deactivated the alarm will clear.
TRK TILT WARN	Truck angle exceeds warning angle (if applicable)	All functions will only operate at 50% of speed.	Move vehicle to level ground. Once vehicle is on level ground the alarm will clear.
TRK TILT ALARM	Truck angle exceeds alarm angle (if applicable)	All functions disabled.	Move vehicle to level ground. Once vehicle is on level ground the alarm will clear.
ANTI-2-BLOCK	Anti 2-Block is activated. Traveling block has come into contact with boom tip.	Disables boom down, extend, and hoist up.	Move load away from boom tip either by retracting, hoisting down, or booming up.
90% LOAD WARN	Reached 90% of rated capacity	Reduces speed of all functions by 50%.	Reduce load to clear alarm.
100% LOAD WARN	Reached 100% of rated capacity	Disables boom down, extend, and hoist up.	Reduce load by either retracting, booming up, or hoisting down to clear alarm.
SLOW ROTATE ACT	Lift cylinder has exceeded 600 psi.	Reduces rotate functions by 50%.	This is a safety feature that prevents excessive swinging of heavy loads. Alarm will reset when load decreases and function is deactivated.
BOOM SENSOR ERR	Boom angle sensor signal failed	All functions are reduced by 50%.	Check connections to boom angle sensor. Verify lights are on at sensor base.
BOOM ANGLE RANGE	Boom angle sensor is out of range	Operates normally.	Boom angle sensor is mounted incorrectly. Check mounting. The arrow should be facing the tip of the crane.
BOOM PT ERR	Boom pressure transducer error	All functions are disabled except boom down and hoist down.	Check connections to pressure transducer located on lift cylinder. Check wiring harness for breaks.

NexStar Troubleshooting

NexStar Error Code Table

INFO BOX	CAUSE	EFFECT	SOLUTION
DIRTY FILTER	Filter is dirty if oil temperature is at least 100 °F	Operates normally.	Replace filter. Auto Crane part number is 366823910.
ADDRESS TAG ERROR	Crane does not recognize address tag	All outputs are disabled.	Check connection at address tag. Check for water in connection. Dry out if necessary.
AUTOSTOW ACTIVE	Crane is currently in auto stow mode	Crane will move into preset stow position while trigger is active.	Selecting any function will disengage auto stow mode.
PERSONNEL BASKET ACTIVE	Crane is currently in personnel basket mode	Disables hoist functions and remaining functions by 50%.	Disengage through mode selection screen. Reference NexStar Operations section for more detail.
STABILITY TEST EXCEEDED	Number of operations in stability test mode has exceeded limit	Disables stability test mode.	If stability test mode is required, please contact Auto Crane technical support.
OIL TEMP WARNING	Oil temperature has exceeded 180 °F (if applicable)	Normal Operation.	Disengage PTO to allow oil to cool. If problem persists, add oil cooler to hydraulic system.
OIL TEMP ALARM	Oil temperature has exceeded 200 °F (if applicable)	Normal Operation.	Disengage PTO to allow oil to cool. If problem persists, add oil cooler to hydraulic system.
ZONE A ACTIVE	Crane is currently located in Zone A base on stability chart (if applicable)	Overload based on Zone A load chart.	Reference stability chart for zone locations. Reference load chart for crane capacities in that zone.
ZONE B ACTIVE	Crane is currently located in Zone B base on stability chart (if applicable)	Overload based on Zone B load chart.	Reference stability chart for zone locations. Reference load chart for crane capacities in that zone.
CW ROT INTO A8	Crane went into overload while rotating clockwise from Zone A to Zone B (if applicable)	Disables clockwise rotation, boom down, and hoist up.	Rotate counter-clockwise to return to Zone A or reduce load to clear alarm.

NexStar Error Code Table

INFO BOX	CAUSE	EFFECT	SOLUTION
CWW ROT INTO A8	Crane went into overload while rotating counter-clockwise from Zone A to Zone B (if applicable)	Disables counter-clockwise rotation, boom down, and hoist up.	Rotate clockwise to return to Zone A or reduce load to clear alarm.
E002 ACTIVITY	Switch or trigger was active when linking transmitter	Disables all functions.	Disengage switch or trigger then push horn button to relink transmitter.
E004 LOW BATTERY	Transmitter batteries are low	Disables all functions and shuts down transmitter.	Charge or tether transmitter.
E006 INACTIVITY	Transmitter has been inactive for a set time and will go to sleep.	All non latching functions will be disabled until transmitter awakens.	Press and release trigger to awaken transmitter.
E007 ESTOP ACTIVE	E-stop has been depressed	Disables all functions.	Pull E-stop to release. Turn transmitter off then back on. Press horn button to relink.

NexStar Troubleshooting

Electrical Troubleshooting Table

PROBLEM	POSSIBLE CAUSE	DIAGNOSIS	SOLUTION
Crane moves unexpectedly	Jammed transmitter button	Activate E-stop to see if movement stops	Verify that nothing had depressed the button as the time of movement. If it was not depressed then replace transmitter.
	Short in harness	Unplug coil to see if movement stops.	Trace wire back to receiver. Verify wire harness is not damaged. Check connectors. They should be clear of debris and water.
	Base station locked up	Turn off transmitter and disconnect base station from harness to see if movement stops.	Turn off crane. Leave off for 2 minutes then turn power back on. If the problem persists contact Auto Crane technical support.
	Controller locked up	Disconnect controller to see if movement stops.	Turn off crane. Leave off for 2 minutes then turn power back on. If the problem persists, contact Auto Crane technical support.
No function operates on the crane.	Transmitter turned off	Verify the power switch is in the on position.	Turn on transmitter
	E-stop is active	Check LCD screen. If E007 error code is shown, then E-stop is active	Pull E-stop to release. Turn transmitter off then back on. Press horn button to relink.
	Crane turned off	Check crane status light. It should be green.	Most cranes have a toggle switch to turn on crane. This is usually located in the cab or crane box.
	Low battery	Check LCD screen. If E004 error code is shown then transmitter is low on battery life.	Charge or tether transmitter.
	Receiver communication	Left LED light on base station should be solid green.	Turn off crane. Leave off for 2 minutes then turn power back on. If problem persists, contact Auto Crane technical support.
	Controller communication	Status light on controller should be blinking amber only.	Turn off crane. Leave off for 2 minutes then turn power back on. If problem persists, contact Auto Crane technical support.
	Truck tilt alarm active	Check screen for error code. It should read "TRK TILT ALARM"	Move vehicle to level ground. Once vehicle is on level ground the alarm will clear.
The following functions are inoperable extend, boom down, hoist up.	Anti-2-Block	Check screen for error code. It should read "ANTI-2-BLOCK"	Move load away from boom tip either by retracting, hoisting down, or booming up.
	Crane overload	Check screen for error code. It should read "100% LOAD WARN"	Reduce load by either retracting, booming up, or hoisting down to clear alarm.

Electrical Troubleshooting Table

PROBLEM	POSSIBLE CAUSE	DIAGNOSIS	SOLUTION
The following functions are inoperable extend, retract, hoist up, boom up, rotate CW, and rotate CCW	Low boom pressure	Check screen for error code. It would read "BOOM PSI LOW"	Hoist down (if applicable) and raise boom off any supports. Alarm will clear once pressure in cylinder is restored.
Rotate CW is inoperable	Reached limit for clockwise rotation.	Check screen for error code, it would read "CW LIMIT"	Verify the CW limit switch is not activated. It should be normally closed.
	Bad coil, or damaged wire	Switch coil with another function coil and check operation. Inspect wire to coil	Replace coil or repair wiring.
Rotate CCW is inoperable	Reached limit for clockwise rotation.	Check screen for error code, it would read "CCW LIMIT"	Verify the CCW limit switch is not activated. It should be normally closed.
	Bad coil, or damaged wire	Switch coil with another function coil and check operation. Inspect wire to coil	Replace coil or repair wiring.
All functions are inoperable except boom down and hoist down.	Pressure transducer is disconnected	Check LCD screen. It would read "BOOM PT ERR"	Verify that pressure transducer located on the lift cylinder valve block is plugged into harness. Inspect wiring going to harness for damage.
Any one function is not operable	Cut in wire or bad coil	Switch coil with another function coil and check operation. Inspect wire to coil	Replace coil or repair wiring.
Crane operates slowly	Slow rotate activated	Check screen for error code. It would read "SLOW ROTATE ACT"	This is a safety feature that prevents excessive swinging of heavy loads. Alarm will reset when load decreases and function is deactivated.
	Close to max crane load	When the truck is tilted and under high load a decrease in rotation speed is possible	Bring load in closer to decrease the moment load.
All functions operate slowly	Truck tilt warning is active	Check screen for error code. It would read "TRK TILT WARN"	Move vehicle to level ground. Once vehicle is on level ground the alarm will clear.
	90% load alarm is activated.	Check screen for error code. It would read "90% LOAD WARN".	Reduce load to clear alarm.
	Boom angle sensor error	Check screen for error code. It would read "BOOM SENSOR ERR"	Check connections to boom angle sensor. Verify lights are on at sensor base.
	Max speed function is lower than 100%	Check screen for speed setting in bottom right of screen. The value shown is the max speed	Reference section 6.8 of this operations manual to change speed selection.

NexStar Troubleshooting

Electrical Harness Schematic

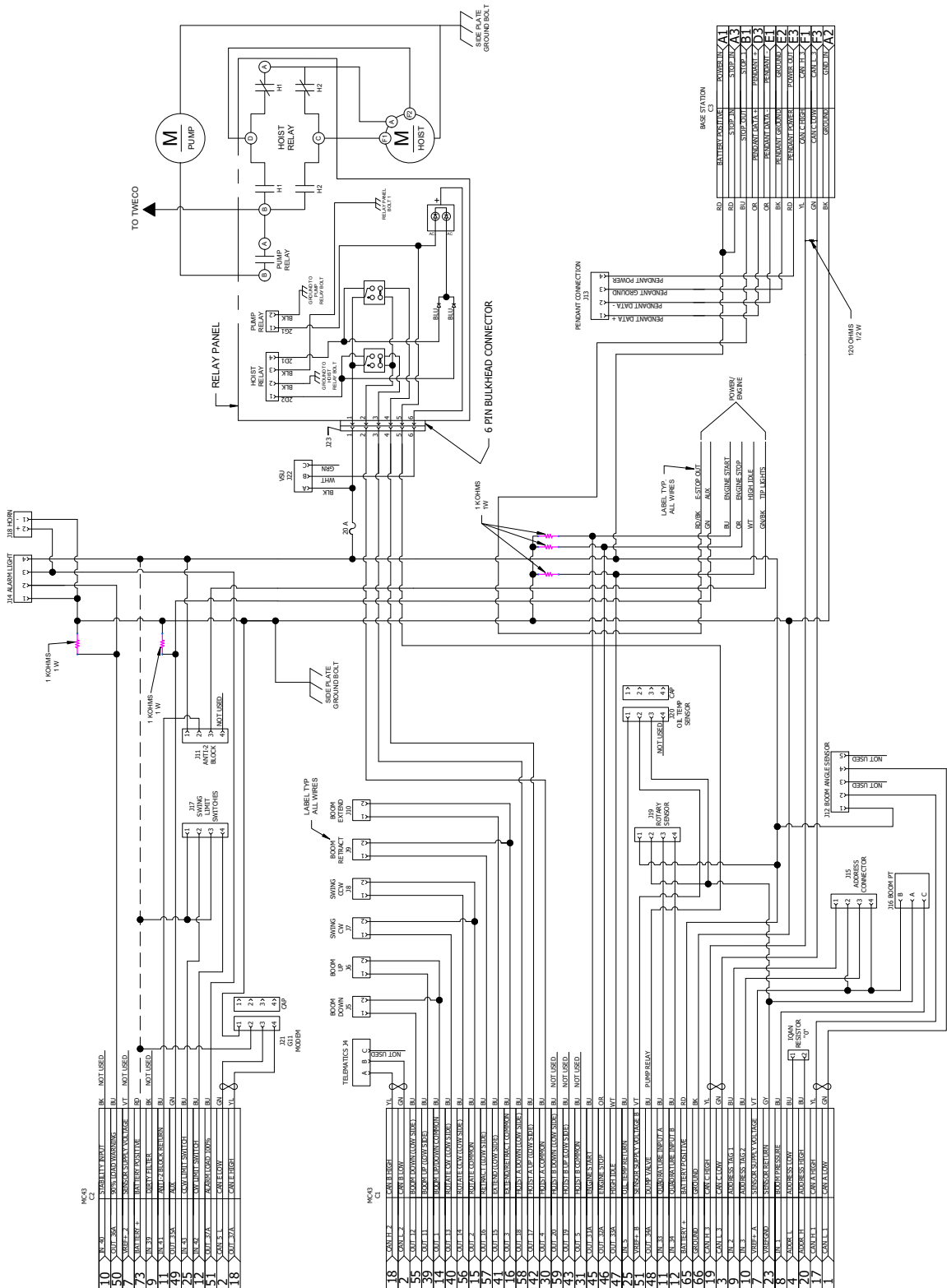

NexStar Troubleshooting

Hydraulic Troubleshooting Table

ERROR	CAUSE	DIAGNOSTIC	SOLUTION
Crane moves unexpectedly	Jammed valve cartridge	Try to manually override valve. If unable to move stem, cartridge is jammed.	Replace valve cartridge.
	Counterbalance valve set too low (boom up and boom down)	Adjust the counterbalance out to see if movement stops.	Contact Auto Crane for proper adjustment and setting of counterbalance valve. Valve may need to be replaced.
	Contaminant in cartridge	Valve sticks in certain positions.	Clean valve to remove debris. Reference Maintenance section for valve cleaning procedure.
No Function Operates On Crane	Hydraulic tank is low or empty	Visually inspect the hydraulic oil level in the tank.	Fill tank to proper level.
	Vehicle is not running	Verify engine is running.	Start vehicle.
	PTO is not engaged	Verify PTO is engaged.	Engage PTO.
All functions operate slowly	Contamination in cartridges	Visually inspect the cartridges for clogged ports.	Clean valves to remove debris. Reference Maintenance section for valve cleaning procedure.
	Relief valve set too low	Install pressure gauge in control valve block. Fully extend boom to induce full pressure. Verify relief pressure.	Adjust relief valve to proper pressure.
Excessive heat during operation	Crane operated too long	Crane operation is generally designed for intermittent duty (15 minutes loaded / 30 minutes cooldown)	Reduce use of crane to allow oil to cool. If problem persists, add hydraulic oil cooler to system.

Hydraulic Schematic

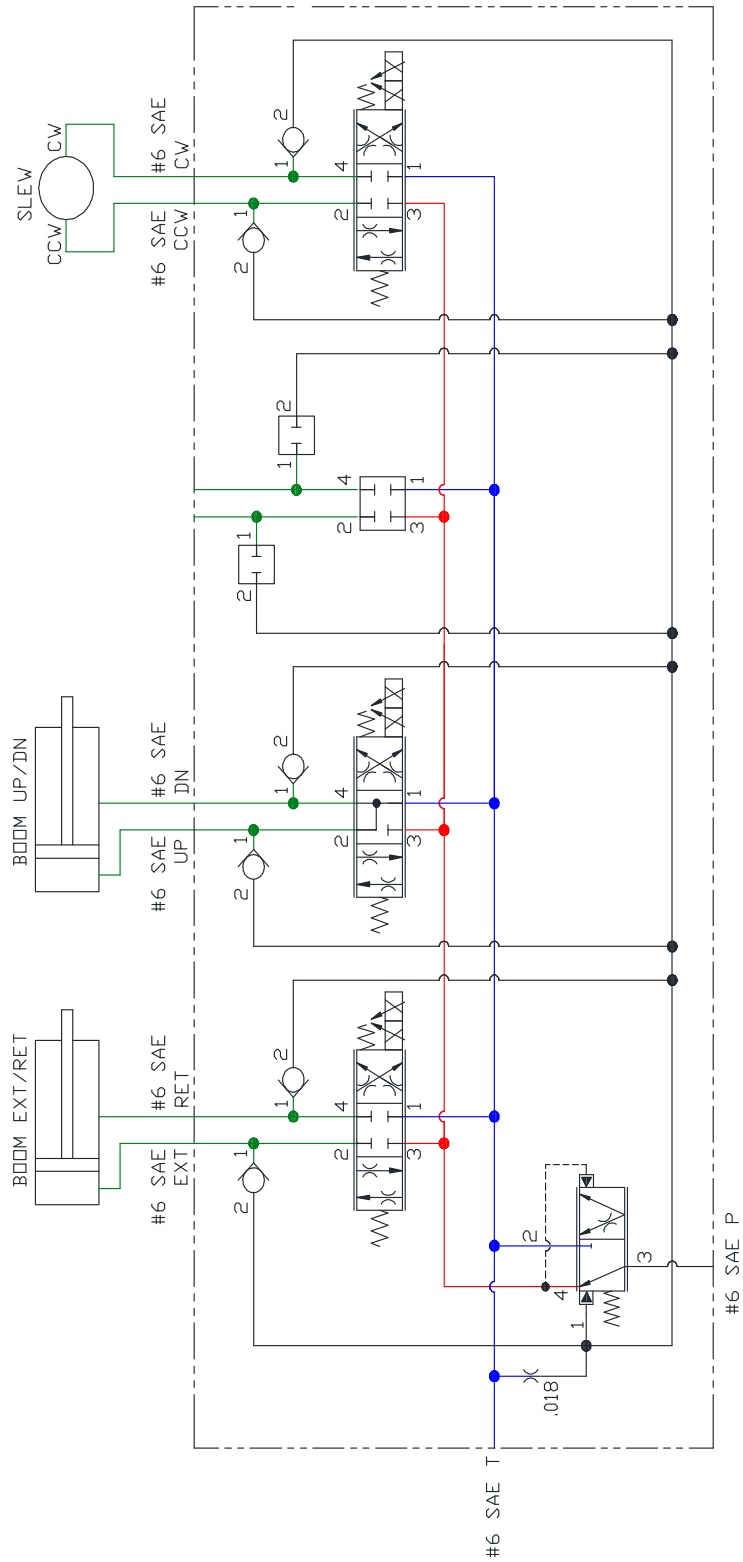

Maintenance

Inspection Requirements

NOTICE

Reference ASME B30.5 and OSHA 1910.180 for complete inspection requirements.

WARNING

All inspections shall be performed by designated personnel only.

Inspection Classification

1. Initial Inspection.
 - A. Prior to initial use, all new, altered, modified, or extensively repaired cranes shall be inspected by a designated person to ensure compliance with provisions of this standard.
2. Regular Inspection.
 - A. Inspection procedures for cranes in regular service are divided into two general classifications based upon the intervals at which the inspection should be performed. The intervals, in turn, are dependent upon the nature of the components of the crane and the degree of their exposure to wear, deterioration, or malfunction. The two general classification are herein designated as "frequent" and "periodic" with respective intervals as defined below:
 - i. Frequent Inspection – daily or before each use.
 - ii. Periodic Inspection – one to twelve-month intervals or as specifically recommended by the manufacturer or qualified person.

Frequent Inspection

Inspections should also occur during operation for any deficiencies that might appear between regular inspections. Any deficiencies, such as those listed below, shall be carefully examined and a determination made as to whether they constitute a hazard:

1. Inspect control mechanisms for maladjustment that interferes with proper operation.
2. Inspect control mechanisms for excessive wear of components and contamination by lubricants or other foreign matter.
3. Inspect safety devices for malfunction.
4. Visually inspect all hydraulic hoses, particularly those that flex in normal operation of crane functions.
5. Inspect hooks and latches for deformation, chemical damage, cracks, and wear.
6. Inspect for proper rope reeving.
7. Inspect electrical wiring and components for malfunctioning, signs of excessive deterioration, dirt and moisture accumulation.
8. Inspect hydraulic system for proper oil level and leaks.
9. Inspect tires for recommended inflation pressure, cuts, and loose wheel nuts.
10. Inspect connecting pins and locking device for wear damage and loose retaining bolts.
11. Inspect rope for gross damage, such as listed below, which may be an immediate hazard.
 - A. Distortion such as kinking, crushing, un-stranding, birdcaging, main strand displacement, or core protrusion. Loss of rope diameter in a short length or unevenness of outer strands should be replaced.
 - B. General corrosion.
 - C. Broken or cut strands.

- D. Use care when inspecting sections of rapid deterioration around flange points, crossover points, and repetitive pickup points on drums.
- E. Inspect number, distribution, and type of visible broken wires.

NOTICE

Continued use of rope depends upon good judgment by a designated person in evaluating remaining strength in a used rope after allowance for deterioration disclosed by inspection. Continued rope operation depends upon this remaining strength.

Periodic Inspection

Any deficiencies, such as those listed below, shall be carefully examined and determination made as to whether they constitute a hazard:

1. Inspect for deformed, cracked or corroded members in the crane structure and entire boom.
2. Inspect for loose bolts, particularly mounting bolts.
3. Inspect for cracked or worn sheaves and drums.
4. Inspect for worn, cracked, or distorted parts such as pins, bearings, shafts, gears, rollers and devices.
5. Inspect for excessive wear on brakes and clutch system parts and linings.
6. Inspect crane hooks for cracks.
7. Inspect travel steering, braking, and locking devices for malfunction.
8. Inspect for excessively worn or damaged tires.
9. Inspect hydraulic hose, fittings, and tubing for the following problems:
 - A. Evidence of leakage at the surface of the flexible hose or its junctions with the metal and coupling.
 - B. Blistering, or abnormal deformation to the outer covering of the hydraulic or pneumatic hose.
 - C. Leakage at threaded or clamped joints that cannot be eliminated by normal tightening or recommended procedures.
 - D. Evidence of excessive abrasion or scrubbing on the outer surface of a hose, rigid tube, or fitting. Means shall be taken to eliminate the interference of elements in contact or otherwise protect the components.
10. Inspect hydraulic pumps and motors for the following problems:
 - A. Loose bolts and fasteners.
 - B. Leaks at joints between sections.
 - C. Shaft seal leaks.
 - D. Unusual noises or vibrations.
 - E. Loss of operating speed.
 - F. Excessive heating of fluid.
 - G. Loss of pressure.
11. Inspect hydraulic valves for the following:
 - A. Cracks in valve housing.
 - B. Improper return of spool to neutral position.
 - C. Leaks at spools or joints.
 - D. Sticking spools.
 - E. Failure of relief valves to attain or maintain correct pressure setting.
 - F. Relief valve pressure shall be checked as specified by the manufacturer.
12. Inspect hydraulic cylinders for the following problems:
 - A. Driving caused by fluid leaking across piston.
 - B. Rod seals leaking.
 - C. Leaks at welding joints.
 - D. Scored, nicked, or dented cylinder rods.
 - E. Damaged case (barrel).
 - F. Loose or deformed rod eyes or connecting joints.

Maintenance

13. Inspect hydraulic filters for evidence of rubber particles on the filter elements indicating possible hose, O-ring, or other rubber component deterioration. Metal chips or pieces on the filter may denote failure in pumps, motors, or cylinders. Further inspection will be necessary to determine the origin of the problem before corrective action can be taken.
14. Inspect labels to confirm correct location and legibility. Reference decals layout in this manual for proper location of decals.
15. Rope inspections need not be at equal calendar intervals and should be more frequent as the rope approaches the end of useful life. A qualified person shall inspect the wire rope based on such factors as:
 - A. Expected rope life as determined by experience on the particular installation or similar installations.
 - B. Severity of environment.
 - C. Percentage of capacity lifts.
 - D. Frequency rates of operation.
 - E. Exposure to shock loads.
 - i. This inspection shall cover the entire length of the rope. Only the surface wires need to be inspected and no attempt should be made to open the rope. Any deterioration resulting in appreciable loss of original strength shall be noted and determination made as to whether use of the rope would constitute a hazard. A few notable deterioration points are listed below:
 1. Reduction of rope diameter below nominal diameter due to loss of core support.
 2. Internal or external corrosion.
 3. Wear of outside wires.
 4. Severely corroded, cracked, bent, worn, or improperly applied connections.

Cranes Not In Regular Use

A crane, which has been idle for a period of more than one month or more, shall be given an inspection conforming to the "initial" and "periodic" inspection requirements of this section.

Inspection Records

Dated records of periodic inspection should be made on critical items such as brakes, crane hooks, rope, cylinders, and relief pressure valves.

Testing Requirements

NOTICE

Reference ASME B30.5 and OSHA 1910.180 for complete testing requirements.

WARNING

All testing shall be performed by designated personnel only. Prior to initial use, all new, altered, modified, or extensively repaired cranes shall be inspected by a designated person to ensure compliance with provisions of this standard.

1. Test all functions to verify speed and operation.
2. Ensure all safety devices are working properly.
3. Confirm operating controls comply with appropriate function labels.
4. Test loads shall not exceed 110% of the manufacturer's load rating.
5. Written reports shall be maintained showing test procedures and confirming the adequacy of repairs.

General Repairs and Maintenance

NOTICE

Reference ASME B30.5 and OSHA 1910.180 for complete maintenance and repair requirements.

WARNING

All repairs and maintenance shall be performed by designated personnel only. Establish a preventative maintenance program based on this section. Obtain all replacement parts from your local authorized distributor.

Maintenance Precautions

1. Place crane where it will cause the least interference with other equipment or operations.
2. Verify all controls are in the OFF position and all operating features secured from inadvertent motion by brakes, pawls, or other means.
3. The means for starting the crane shall be rendered inoperative.
4. The boom should be secured in place before maintenance.
5. Relieve hydraulic oil pressure from all hydraulic circuits before loosening or removing hydraulic components.
6. WARNING or OUT OF ORDER signs shall be placed on all crane controls.
7. After adjustments and repairs have been made, the crane shall not be returned to service until all guards have been reinstalled, trapped air removed from hydraulic system (if required), safety devices reactivated, and maintenance equipment removed.

Adjustments and Repairs

1. Any hazardous conditions disclosed by the inspection requirement shall be corrected before operation of crane is resumed.
2. Adjustments shall be maintained to assure correct functioning of components, the following are examples:
 - A. Function operating mechanism.
 - B. Safety devices.
 - C. Control systems.
3. Repairs or replacements shall be provided as needed for operation; the following are examples:
 - A. Critical parts of functional operating mechanisms which are cracked, broken, corroded, bent, or excessively worn.
 - B. Critical parts of the crane structure which are cracked, bent, broke, or excessively corroded.
 - C. Crane hooks showing cracks, damage, or corrosion shall be taken out of service.
4. If bleeding the hydraulic system is required, run each crane function until smooth operation of that particular function is noticeable.

Lubrication

All moving parts of the crane, for which lubrication is specified, should be regularly lubricated per the manufacturer's recommendations and procedures.

Maintenance

Rope Replacement

No precise rules can be given for determination of the exact time for replacement of rope, since many variable factors are involved.

NOTICE

Replacement rope shall have a strength rating at least as great as the original rope furnished or recommended by Auto Crane. A rope manufacturer, Auto Crane, or a qualified person shall specify any deviation from the original size, grade, or construction.

Conditions such as the following shall be reason for questioning continued use of the rope or increasing the frequency of inspection:

1. In running ropes, six randomly distributed broken wires in one strand in one lay.
2. One outer wire broken at the contact point with the core of the rope structure and protrudes or loops out of the rope structure. Additional inspection of this section is required.
3. Wear of one third of the original diameter of the outside individual wire.
4. Kinking, crushing, bird caging, or any other damage resulting in distortion of the rope structure.
5. Evidence of any heat damage from any cause.
6. Reduction of nominal diameter of more than:
 - A. 1/64" (0.4mm) – for diameters up to and including 5/16" (8mm)
 - B. 1/32" (0.8mm) – for diameters 3/8" (9.5mm) through and including 1/2" (13mm)
 - C. 3/64" (1.2mm) – for diameters 9/16" (14.5mm) through and including 3/4" (19mm)
 - D. 1/16" (1.6mm) – for diameters 7/8" (22mm) through and including 1-1/8" (29mm)
 - E. 3/32" (2.4mm) – for diameters 1-1/4" (32mm) through and including 1-1/2" (38mm).
7. In standing ropes, more than two broken wires in one lay in sections beyond end connections or more than one broken wire at an end connection.

Rope Installation and Maintenance

1. Rope should be stored to prevent damage and deterioration.
2. Unreeling or uncoiling of rope shall be done as recommended by the rope manufacturer and with care to avoid kinking or inducing twist.
3. Before cutting a rope, seizing shall be placed on each of the place where the rope is to be cut to prevent unlaying of the strands. On preformed rope, one seizing on each side of the cut is required. On non-preformed ropes of 7/8" (22mm) or smaller, two seizings on each side of the cut are required. For non-preformed rope 1 in. (25mm) diameter or larger, three seizings on each side of the cut are required.
4. During installation care should be exercised to avoid dragging of the rope in the dirt or around objects that will scrape, nick, crush, or induce sharp bends in it.
5. Rope should be maintained in a well-lubricated condition. It is important that lubricant applied as a part of the maintenance program shall be compatible with the original lubricant, and to this end the rope manufacturer should be consulted. Lubricant applied shall be the type that does not hinder visual inspection. Those sections of rope that are located over sheaves or otherwise hidden during inspection and maintenance procedures require special attention when lubricating rope. The object of rope lubrication is to reduce internal friction and to prevent corrosion.
6. When an operating rope shows greater wear or well-defined localized areas than on the remainder of the rope, rope life can be extended in some cases by shifting the wear to different areas of the rope.

Paint Finish Maintenance

The paint finish on Auto Crane products can become damaged during normal use when chipped, scratched, exposed to harsh chemicals, cleaned with pressure washers, or similar. During periods when the truck is exposed to salt or other corrosive chemicals, wash Auto Crane products weekly. Inspect the paint finish monthly or when washed. Immediately repair any exposed bare metal or rust. Repair damaged paint on Auto Crane products with the following procedure:

1. Sand the damaged area to bare metal.
2. Use a solvent to clean the sanded area to remove sanding debris and residue.
3. Wipe dry with a clean cloth to remove any remaining debris and residue.
4. Use a primer compatible with PPG Spectracron 573.
5. Prime the sanded areas to a minimum 2 mil dry film thickness per the primer manufacturer's instructions.
6. Use a paint compatible with PPG Spectracron 573 epoxy primer and PPG Spectracron QT360HW topcoat paint.
7. Apply the topcoat paint to a minimum 2 mil dry film thickness within 24 hours of applying the primer.
8. The final primer and topcoat should have approximately a 4 mil dry film thickness.

Maintenance

Lubrication and Maintenance Schedule

Service Performed	Instructions	Daily	Weekly	3 Months	Yearly
Load Hook	Inspect hook and latch for deformation, cracks, and corrosion	X			
Cable Drum	Ensure cable is wound evenly on drum	X			
Hoist Cable	Check for flattening, kinks, broken strands	X			
Hyd. Hoses	Visual inspection	X			
Hyd. Fluid	Check fluid level	X			
Pin Retaining Bolts	Check torque to 23 ft-lb (Grade 5), 35 ft-lb (Grade 8) as required	X			
Mounting Bolts	Check torque to 501 ft-lb (Gr 8 hex head), 475 ft-lb (socket head)		X		
Rotating Ring Gear	Lube with MobileTac LL, Lubriplate or equivalent		X		
Sheave Bearings	Sealed bearing, replace if rough or loose		X		
All Other Bolts	Check and tighten as required		X		
Lift Cylinder Bearings	Grease with MobilePlex EP-2 or equivalent at zerk fittings			X	
Rotation Bearing	Grease with MobilePlex EP-2 or equivalent at zerk fittings			X	
Rotation Bearing Bolts	Check torque to 225 ft-lb			X	
Hoist Mounting Bolts (HC-10, 12S, 12, 14)	Check torque to 173 ft-lb			X	
Hoist Mounting Bolts (All others)	Check torque to 85 ft-lb			X	
Slewing Drive (HC-7x/8x)	Grease with MobilePlex EP-2 or equivalent at zerk fittings			X	
Hydraulic Fluid	Drain, flush, and refill with Superfilm 5W-20 or equivalent				X
Rotation Gearbox (HC-12/14)	Drain, flush, and refill with 52 oz of GL-5 EP-80/90 gear oil				X
Rotation Gearbox (All Others)	Drain, flush, and refill with 58 oz of EP-140 gear oil				X
Boom Slide Pads	Pads greased when replaced				
Filter, Valve Block	Replace annually, every 200 hours of operation, or as directed by the dirty filter sensor				
For additional information, see OSHA 1910.180 and ASME B30.5					

Lubrication Points

1. Use only authorized parts/lubrication. Any damage or malfunction caused by the use of unauthorized parts is not covered by Warranty or Product Liability.
2. Once a bolt has been tightened to specification then removed, the bolt should be replaced with a new one. Auto Crane Company recommends this crane be serviced per the "Crane Inspection Log" P/N 999978. Fill these logs in at the intervals noted and kept as a permanent record. Additional copies are available from your local distributor.

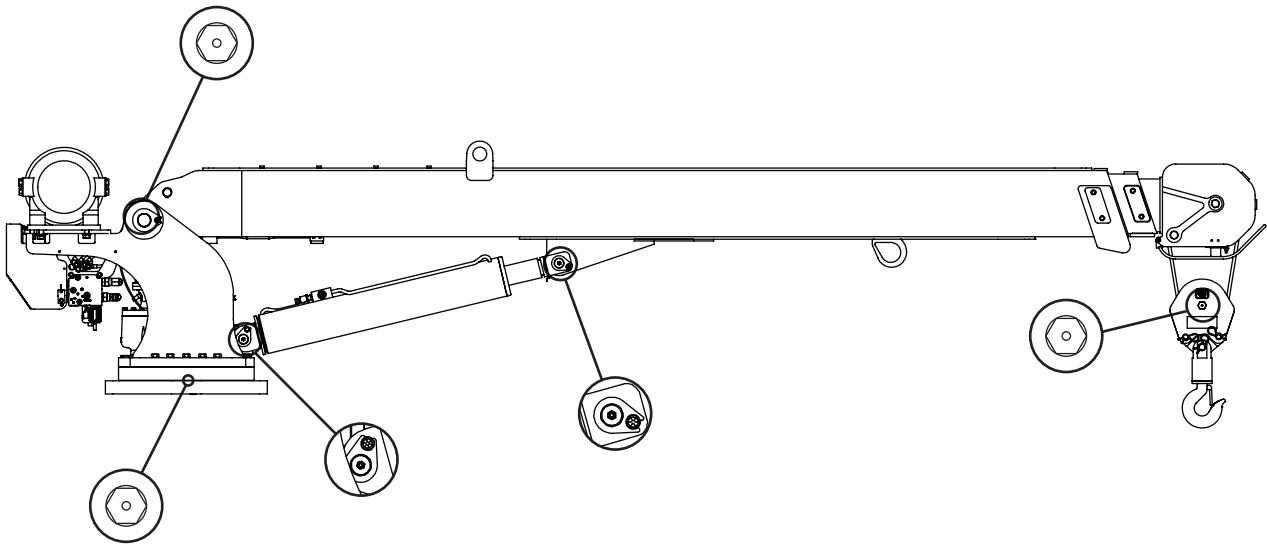

Maintenance

NexStar Control Valve Cartridge Maintenance



Verify movement in ports while manually overriding cartridge



Use the following procedure to inspect the cartridge for proper operation:

1. Clean the area around the valve spool before it is removed from the valve bank.
2. Remove the valve spool from the valve bank. Be careful not to touch any surrounding objects.
3. Use any of the shelf automotive brake cleaning fluid to remove any visible debris from the valve spool. Wear skin and eye protection while spraying the valve spool clean.
4. Inspect the O-rings for damage. Replace if necessary.
5. While collar is pulled back, valve should slide freely.
6. Dip the valve spool into fresh hydraulic fluid to lubricate and fill the cavities.
7. Install the valve spool into the valve block.
8. Validate the operation of the crane related to this valve spool.

Rotation Bearing Replacement

All bearings wear over time, including the main rotation bearing of the crane. There are no precise rules for replacing the main rotation bearing because of many variable factors. There are common symptoms during crane operation that may indicate rotation bearing wear. These include:

1. Excessive noise.
2. Rough rotation.
3. Increase drive power required to rotate.
4. Metal particles in grease.

Replace the Bearing If:

1. Any noticeable cracking in the bearing housing.
2. Damage to internal teeth.
3. Excessive axial play is present. See Axial Play Allowance Check Procedure.



Never try to repair a rotation bearing. For a replacement bearing contact your local authorized distributor.

Axial Play Allowance Procedure

1. Raise the boom to the maximum angle and measure the clearance between base plate and the rotation bearing with a dial or filler gauge.
2. Lower the boom to the horizontal position and measure the clearance between the base plate and the rotation bearing with a dial indicator or feeler gauge.
3. If the difference between the two measurements exceeds the specification, replace the bearing.
4. Rotate crane 45°, then repeat steps 1 and 2 until you reach 360° of rotation.

Crane Model	Axial Play Allowance	Rotation Bearing Replacement Kit
EC-2X, EHC-3.2, HC-3.2, EHC-4	1.5 mm	320878010
EHC-5, EHC-6, HC-5, HC-6, HC-7, HC-8, 8406H, HC-9	1.6 mm	480023010
HC-7x, HC-8x	0.1 mm	479200220
HC-10, HC-12S	1.8 mm	372064010
HC-12, HC-14	2.3 mm	470001010
HC-5, HC-6, EHC-5, EHC-6	0.1 mm	492000322

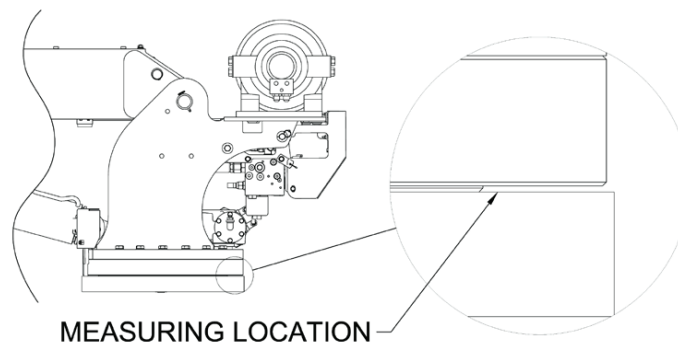

Maintenance

Electric Hoist Maintenance and Operation

Weekly

1. Check the oil level and maintain it to the oil level plug. If oil is leaking out, determine location and repair.
2. Check the pressure relief plug in top of the gear housing. Be sure that it is in good operating condition so that hot oil gasses may escape.
3. Lubricate cable with light oil.

Monthly

1. Lubricate the various grease fittings located in the cable drum, end bearing, clutch housing or clutch operating linkage. Any good grade of moly-disulfide containing grease is acceptable.
2. Check the hoist mounting bolts. If any are missing, replace them and securely tighten any that are loose. Make sure to use only grade 5 bolts or better.
3. Check the torque setting of the oil cooled worm brake. Reference brake adjustment.
4. Inspect the cable. If the cable has become frayed with broken strands, replace immediately.

Annually

1. Drain the oil from the hoist annually or more often if winch is used frequently.
2. Refill the hoist to the oil level plug with all-purpose EP 140 gear oil.
3. Inspect frame and surrounding structure for cracks or deformation.
4. Gear wear can be estimated by rocking the drum back and forth and if necessary, drain oil and remove cover for closer inspection.

The uneven spooling of cable while pulling a load is not a problem unless there is a cable pileup on one end of the drum. If this happens, reverse the winch to relieve the load and move your anchor point further to the center of the vehicle. After the job is done you can unspool and rewind for a neat lay of the cable.

Check oil level of hoist every six months. Replace oil annually or more often if hoist is used frequently. Use 12 ounces of all-purpose EP 140 gear oil in the worm gear housing and 8 ounces of SAE 20 oil in the spur gearbox. If the oil is contaminated with metallic particles, inspect winch for cause of abnormal wear. Periodically check all electrical connections and mounting bolts.

Rotation Gearbox/Slewing Drive Maintenance

For HC-5, HC-6, HC-7, HC-8, 8406H, HC-9, HC-10, and HC-12S models:

Check the gearbox oil level to ensure gearbox is well lubricated and stays in good operating condition. In order to extend gearbox operating life, it is recommended that the gearbox oil is drained annually and refilled with 28 ounces of EP 140 gear oil.

For HC-7x, HC-8x models:

Grease with MobilePlex EP-2 or equivalent at all zerk fittings.

For HC-12, HC-14 models:

Check the gearbox oil level to ensure gearbox is well lubricated and stays in good operating condition. In order to extend gearbox operating life, it is recommended that the gearbox oil is drained annually and refilled with 52 ounces of GL-5 EP-80/90 gear oil.

Brake Adjustment

The oil-cooled, fully adjustable, automatic safety brake operates in the work housing lubricant, with all parts being submerged in oil. When the brake wears to the point that the load begins to drift, the brake can be adjusted using an adapter can be made with a slotted piece of pipe or tubing having an inside diameter of 0.75", an endcap, and a nut as depicted below:

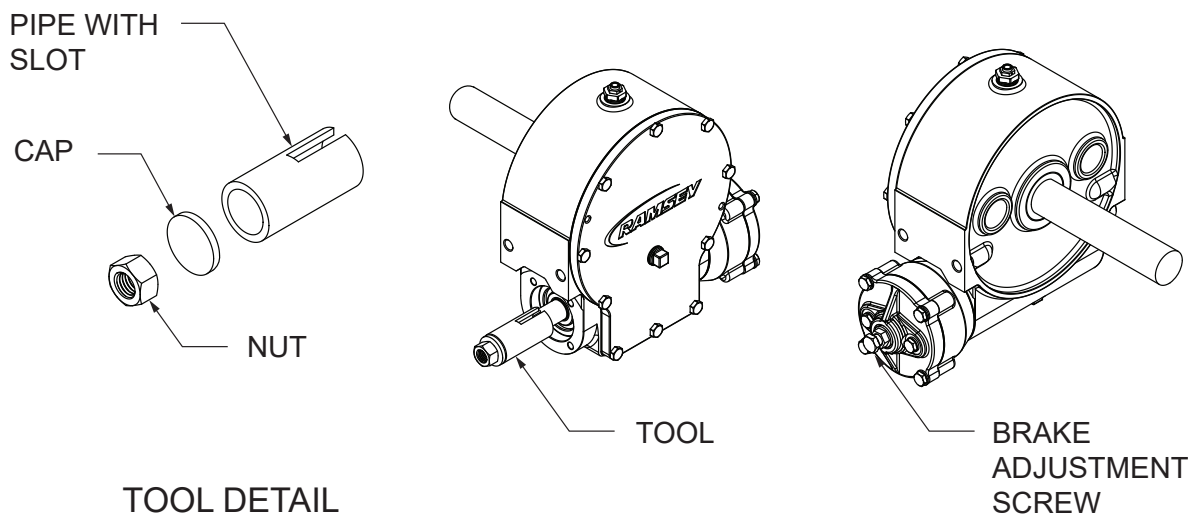

After welding the cap and nut to the pipe or tubing, slot the pipe or tubing as show to allow the adapter to slide around the key in the shaft. This will allow the adapter to act as a large socket that can be used with a **beam-style** torque wrench to determine the rolling torque of the shaft.

Turn the torque wrench so that the drum turns in the direction that lowers the cable. The rolling torque value should be between 8 and 13 ft-lb.

If the torque wrench indicates that the torque is **less** than 8 ft-lb.:

1. Loosen the lock nut on the adjusting screw.
2. Turn the adjustment screw $\frac{1}{4}$ turn **clockwise**.
3. Tighten the lock nut on the adjusting screw.
4. Re-measure torque.

If the torque wrench indicates that the torque is **more** than 13 ft-lb.:

1. Loosen the lock nut on the adjusting screw.
2. Turn the adjustment screw $\frac{1}{4}$ turn **counterclockwise**.
3. Tighten the lock nut on the adjusting screw.
4. Re-measure torque.



Only $\frac{1}{4}$ turn is usually required to adjust the brake. Over-tightening can cause overheating and damage to the brake parts.

If the brake does not respond to adjustment, a new leaf spring and brake disc may be required.

Maintenance

Eccentric Ring Adjustment

1. Remove retaining clip from bottom of crane.
2. Rotate eccentric ring to tighten or loosen backlash.

NOTICE

Important: The tooth gap should be between 0.005" and 0.007" at the blue/green mark on the rotation bearing. This can be checked using Plastigauge®.

3. Once adjusted, reattach eccentric ring retaining clip by inserting into one of the holes on the eccentric ring and tightening the mounting bolt.

NOTICE

On new units, slight metal and/or paint shavings may develop during initial operation. This is considered normal gear wear-in.

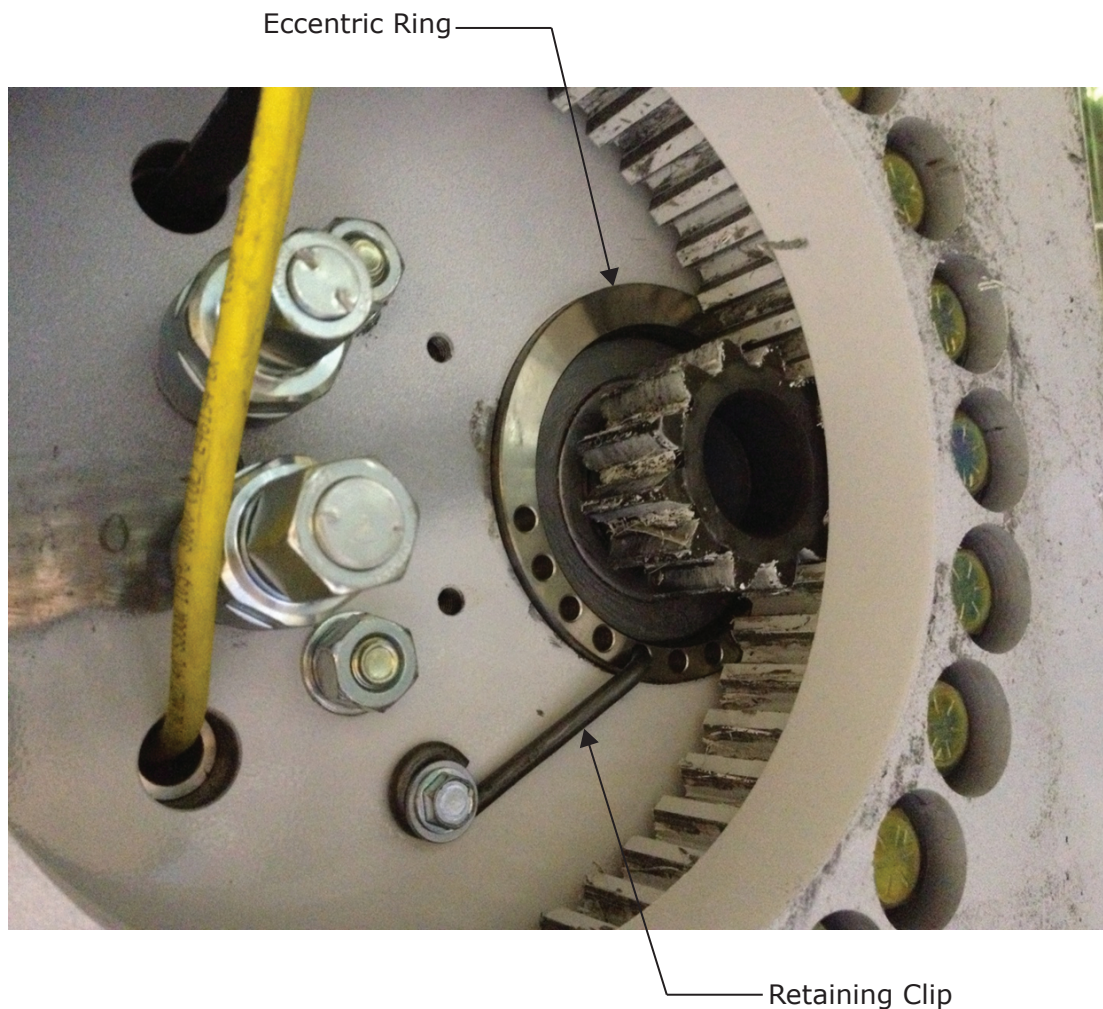

General Installation

For information specific to your crane, such as mounting hole diameter, bolt size and grade, and hydraulic requirements, see General Dimensions.

1. Reference General Dimensions for minimum chassis GVWR needed for crane.
2. The vehicle must be equipped with an engine speed control and tachometer.
3. Ensure the mounting surface is properly reinforced to withstand the capacity loading of the crane. Ensure the Outriggers are used to provide total stability for the truck.
4. If not using an Auto Crane body, cut the proper sized hole in the mounting location (centered with mounting bolts) for access to hydraulic connections.
5. Ensure the mounting bolts are the proper size and grade and torque to 501 ft-lb.
6. Pressure and return hoses are not furnished with the crane and must be supplied by the installer with lengths determined at installation. Reference General Specifications for pressure and flow requirements.



CAUTION

Maintain ISO 18/16/13 fluid cleanliness levels. Failure to use clean hydraulic hoses and components may contaminate the crane and hydraulic system and void warranty.

NOTICE

Excess flow will cause erratic operation and too little flow will cause poor crane operation.

IMPORTANT: The recommended hydraulic reservoir size for the average industry application CRANE ONLY installation is two times the crane hydraulic flow rate. For crane applications requiring more than 25% crane operation time while the PTO is engaged and/or additional equipment is operated by the same hydraulic system, it is recommended that an appropriately sized, larger hydraulic reservoir and/or a forced air hydraulic oil cooler be installed. The addition of other auxiliary hydraulic equipment will require additional capacity.

Installation

Each crane arrives with a shipping tote that contains the following items:

ITEM NO.	QTY	PART NUMBER	DESCRIPTION
1	4	015100000	7/8-14 X 4 HH GR 8
2	1	022200000	WASHER SP LK 7/8
3	4	018900000	NUT HX 7/8 NFCP GR8
4	6	083800000	CLIP, CABLE #838
5	1	990800008	MANUAL, EHC-6, NEXSTAR
6	1	366800224	DECAL, LOAD CHART, EHC-6
7	1	366066000	TRAVELING BLOCK ASSY, LESS 2-BLOCK BAR 6006EH
8	1	479824002	DECAL, STABILITY CHART
9	1	479824003	DECAL, STABILITY CHART, CUSTOM ZONE PERCENTAGES
10	1	320988009	KIT, ALIGNMENT DECAL LOCATION
11	1	715321032	SHIPPING TOTE, 15 GAL, BLACK / RACER RED
12	1	366823400	REMOTE, NEXSTAR
13	1	366823401	DOCKING STATION, REMOTE
14	1	366823406	BATTERY PACK, AA ALKALINE (X3), NEXSTAR
15	1	366823427	CABLE, TETHER, 10M, NEXSTAR

Please check to make sure the above items have been supplied with your crane. If any items are missing, please notify your dealer, or contact Auto Crane.

General Electrical Hookup

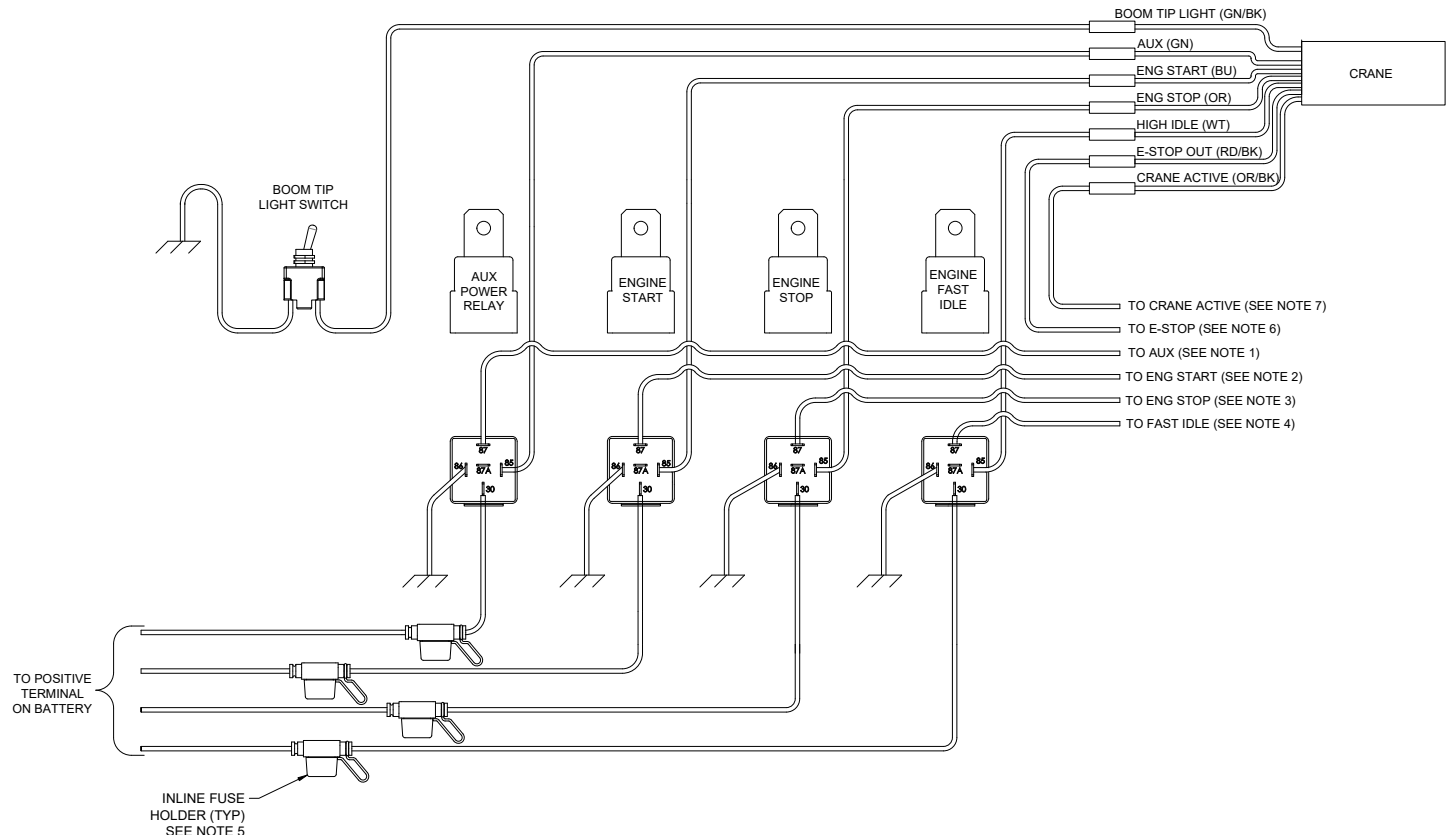

Notes:

1. If using compressor, attach to switched power wire.
2. Attach to chassis wiring for remote engine start. Reference respective chassis' body builder's handbook for location and wiring requirements.
3. Attach to chassis wiring for remote engine stop. Reference respective chassis' body builder's handbook for location and wiring requirements.
4. Attach to chassis wiring for high idle. Reference respective chassis' body builder handbook for location and wiring requirements. Some chassis high idle when PTO is activated.
5. Can use fuse block in place of inline fuses.
6. E-Stop wire provides 12 VDC+ when Emergency Stop on remote is activated. If E-stop out is not used, ensure that the wire end is sealed and/or away from anything it can ground to if the Emergency Stop is activated.
7. Crane Active wire provides 12 VDC+ when dump valve on crane is activated during any hydraulic function. If Crane Active is not used, ensure that the wire end is sealed and/or away from anything it can ground to if the dump valve is activated.



Failure to correctly plumb and wire crane can cause inadvertent operation and damage to crane and/or personnel.

IMPORTANT: Follow all federal laws pertaining to final stage manufacturers and crane stability requirements. Reference the Safety Tips and Precautions section for specifics.

Installation

Voltage Switching Unit Installation

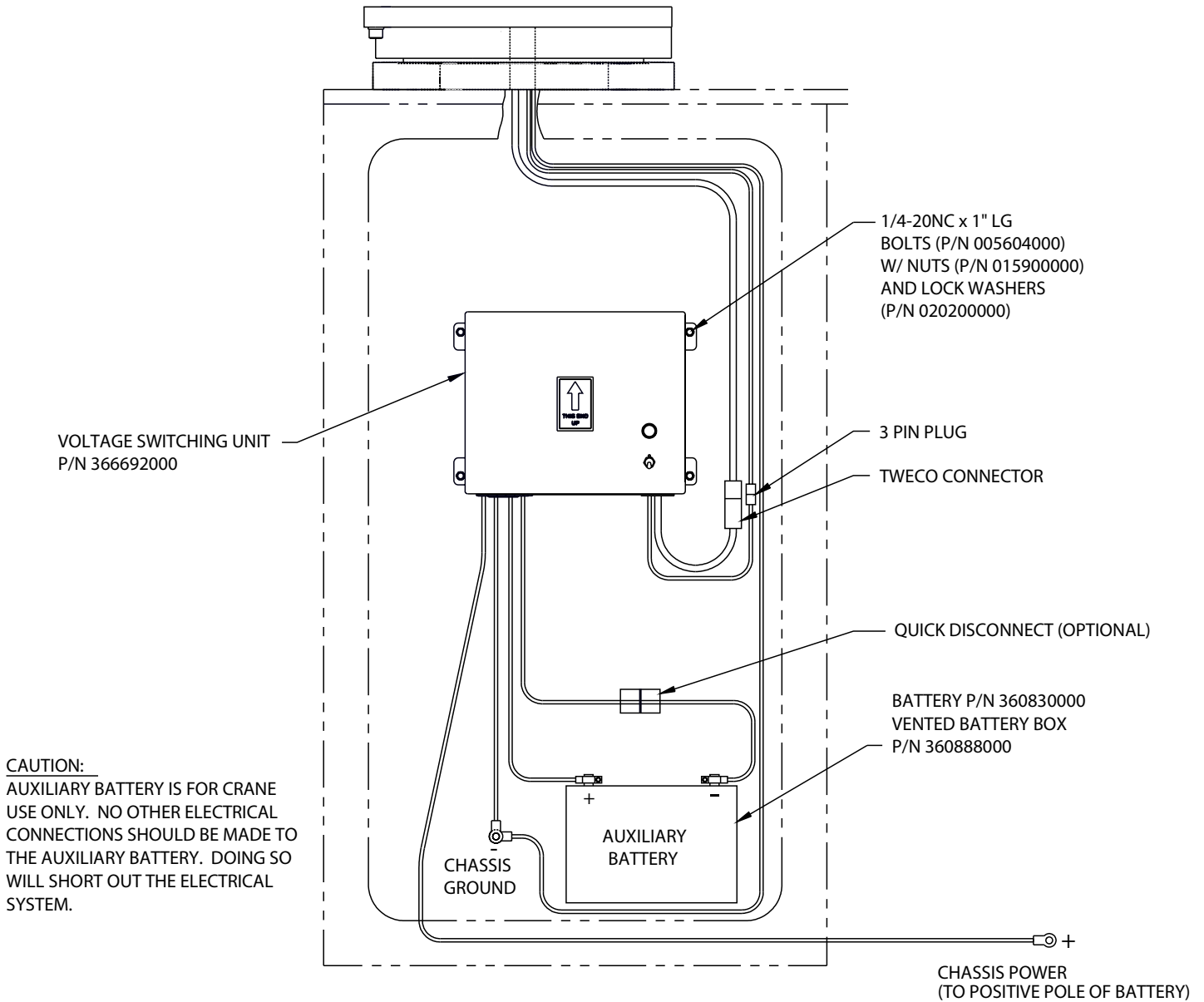

Voltage Switching Unit

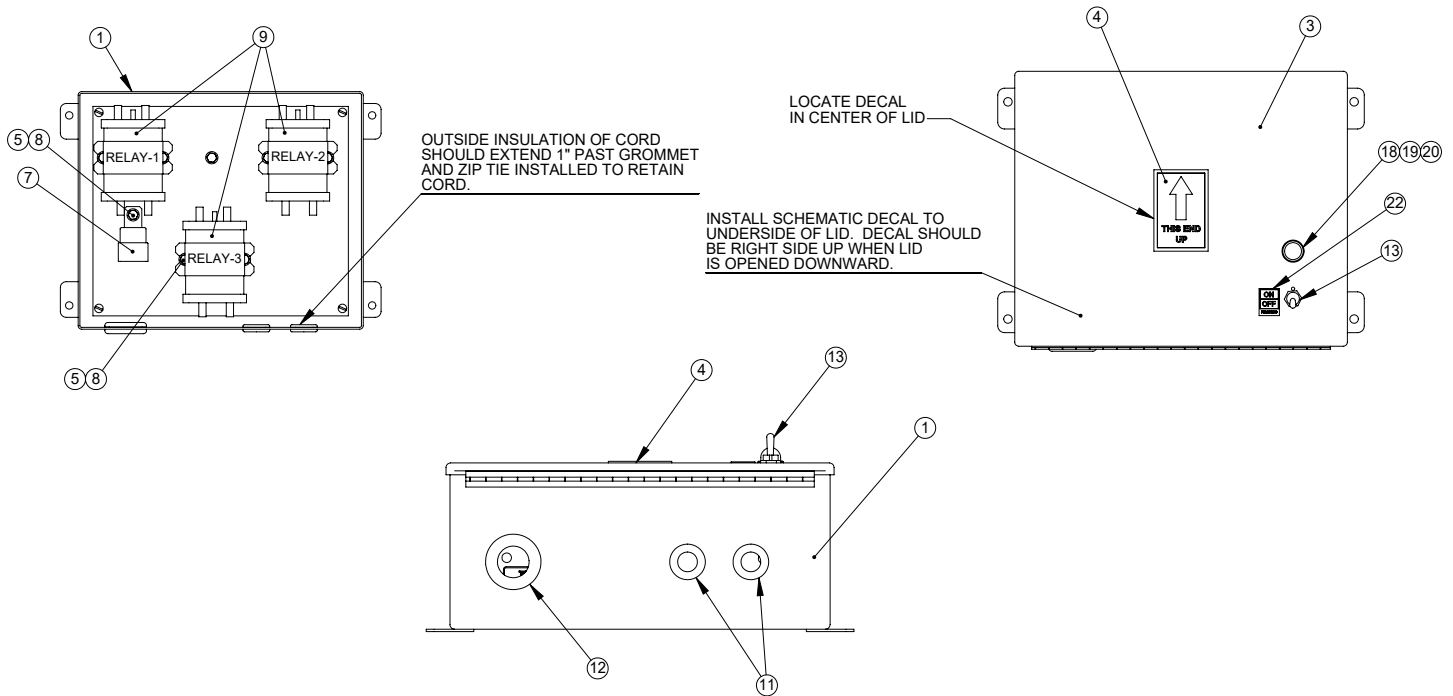

ITEM NO.	QTY	PART NUMBER	DESCRIPTION
1	1	366693000	ENCLOSURE, VOLTAGE SWITCHING UNIT
2	1	367242001	DECAL, THIS END UP
3	8	736272000	NUTSERT 1/4-20UNC X .027-.165 GRIP
4	1	320355000	RELAY, BOSCH
5	8	360493000	SCREW HX WHIZ-LK 1/4-20UNC X 1/2 LG
6	3	404167000	SOLENOID, SEALED
7	2	750169000	GROMMET, RUBBER
8	1	750282000	GROMMET, RUBBER, 1.375 OD, 1.00 ID
9	1	750090000	TOGGLE SWITCH, 1 POLE, 2 POSITION
10	1	360763001	HOUSING DEUTSCH 3-PIN
11	1	360763002	WEDGE, DEUTSCH 3-PIN
12	3	366367003	CONTACT, DEUTSCH SOCKET
13	1	366705000	DECAL, VSU SCHEMATIC
14	1	750171000	LAMP SOCKET, INDICATOR
15	1	750173000	BULB, 12V TYPE T-2
16	1	366707000	LENS, GREEN FLUTED
18	1	366717000	TWECO CONNECTOR, FEMALE 1MPC2
19	1	366516000	DECAL, ON/OFF

Installation

Docking Station

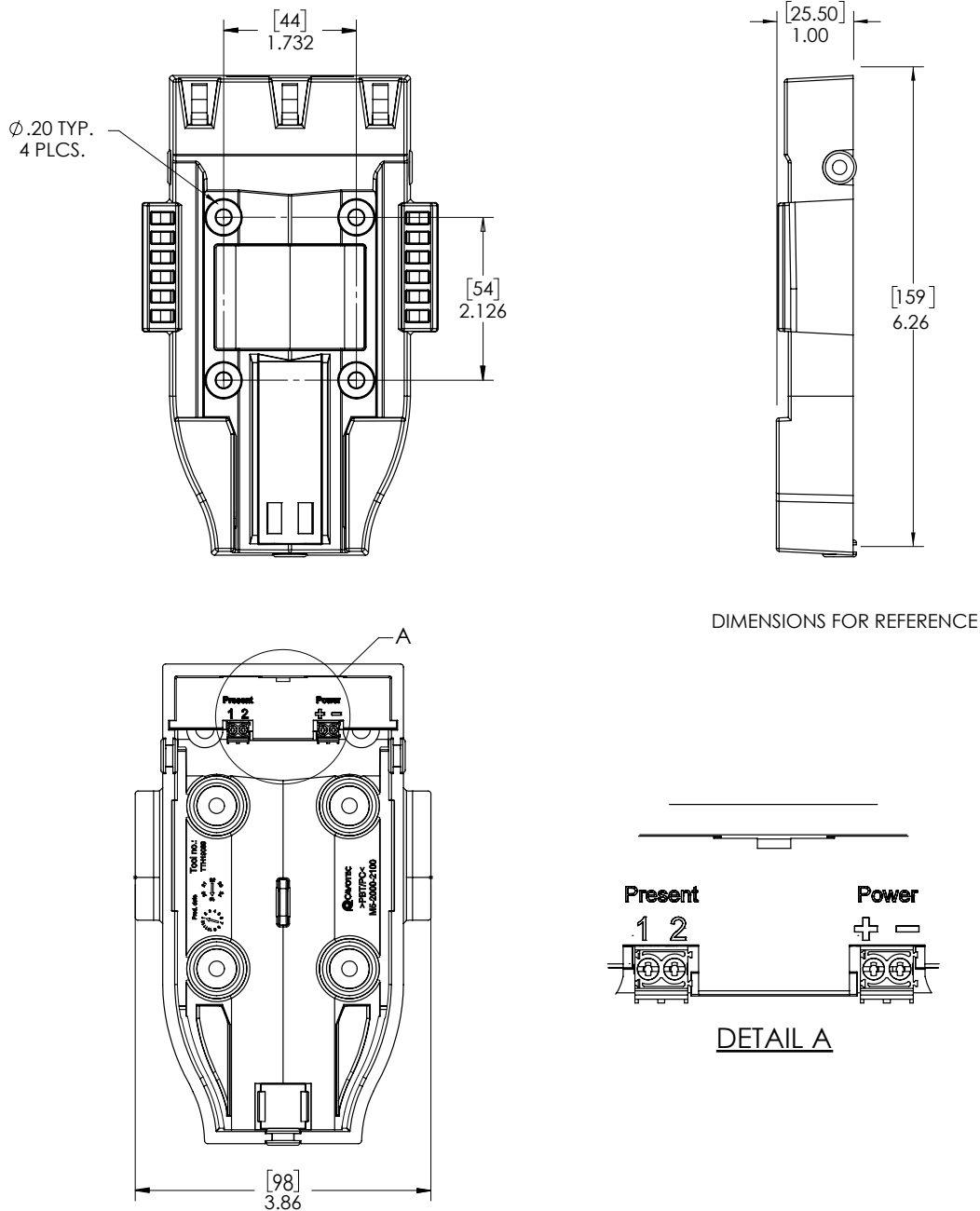

To wire the docking station, use an unswitched and fused 12 VDC+ power source to ensure remote charging when the vehicle is off. Connect this power supply to the "Power +" terminal on the dock and ground the "Power -" terminal to the vehicle. Terminal 1 and Terminal 2 will be equal when the remote is not in the docking station. Terminal 2 is used only as a signal and should not be used with any type of load.

Auto Crane offers a cradle kit, P/N 366823460, that includes a chime that indicates that the remote has not been returned to its cradle when not in use.

Stability Chart Installation

There is a stability chart included in the ship kit. This decal is typically installed on the inside of the door of the crane box. This decal is to alert the user of the available crane capacities around the vehicle.

479824002 decal will be installed on an Auto Crane body that was outfitted with an Auto Crane crane and Auto Crane Outriggers. Auto Crane has designed the body, crane and Outrigger to have stability based on the chart below:

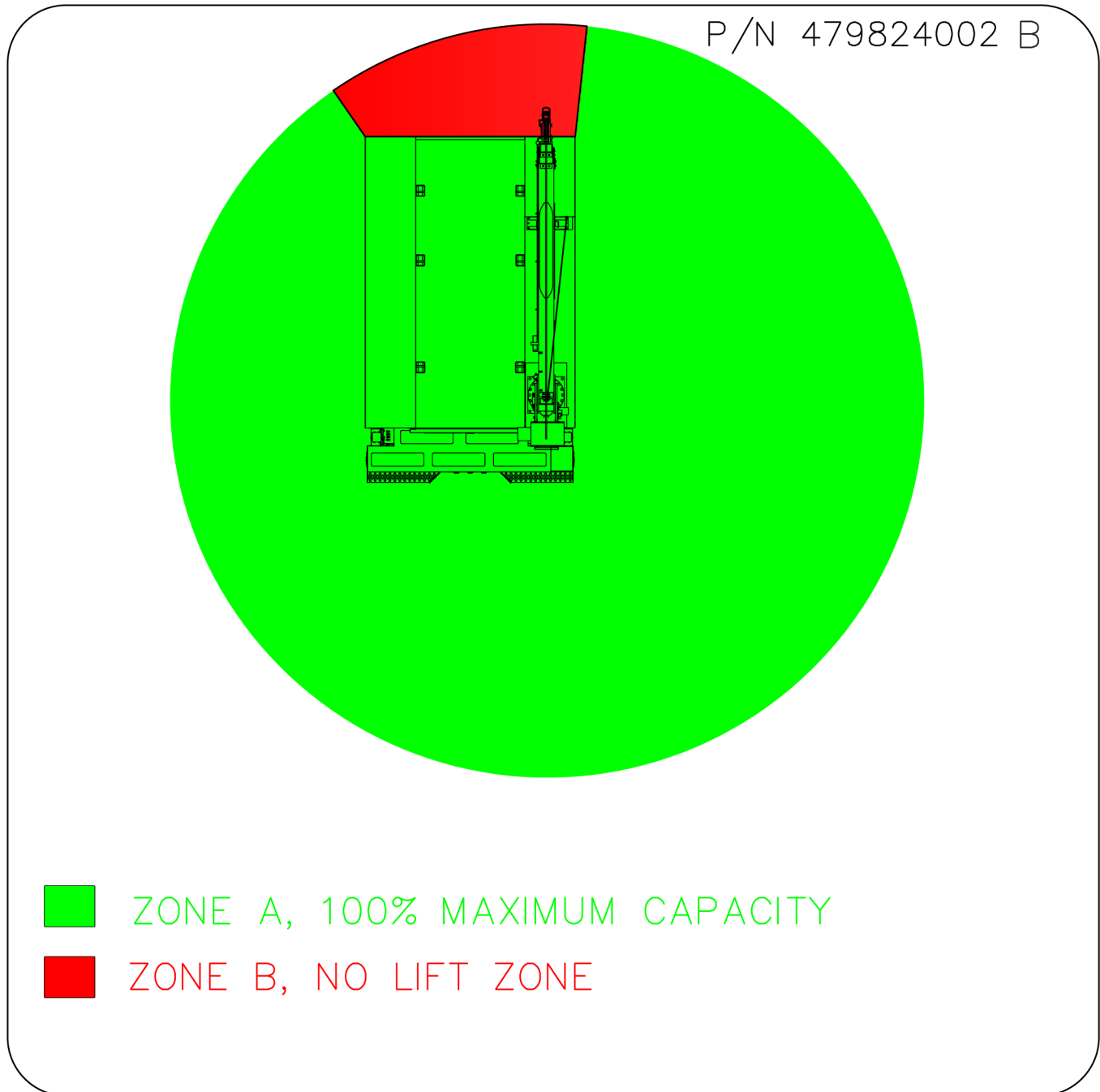

Installation

479824003 decal will be installed on an Auto Crane body that was not outfitted with an Auto Crane crane and Auto Crane Outriggers. The stability chart provides lines to write in the tested stability percentage at each section below:

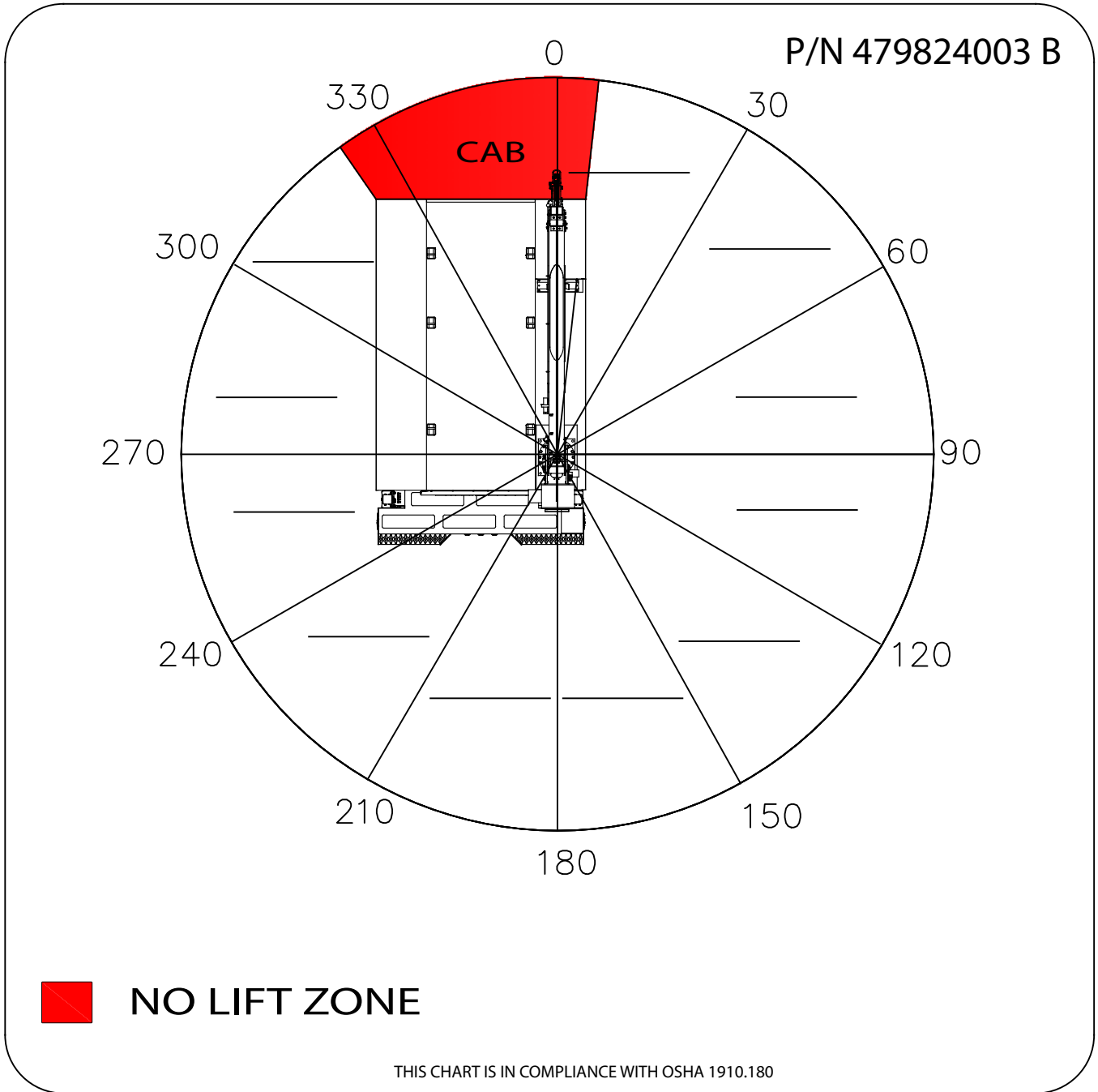

Large Crane Serial Number Location

The serial number is stamped into the left top side plate of the pedestal as well as the decal on left side plate as shown below.

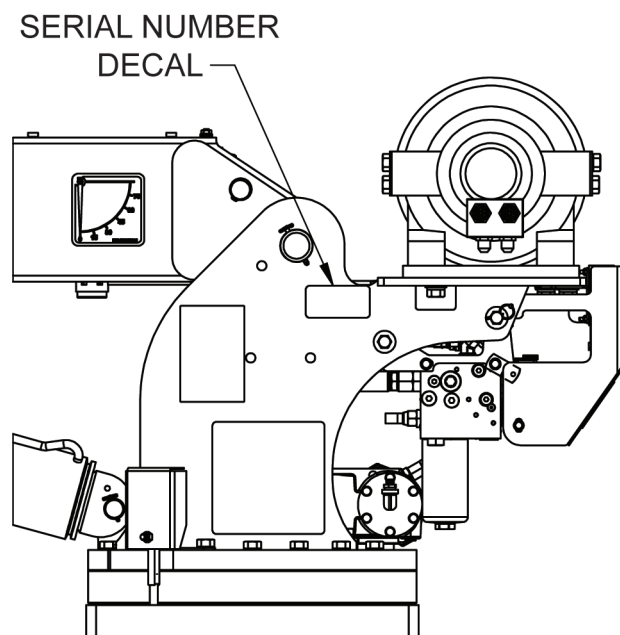
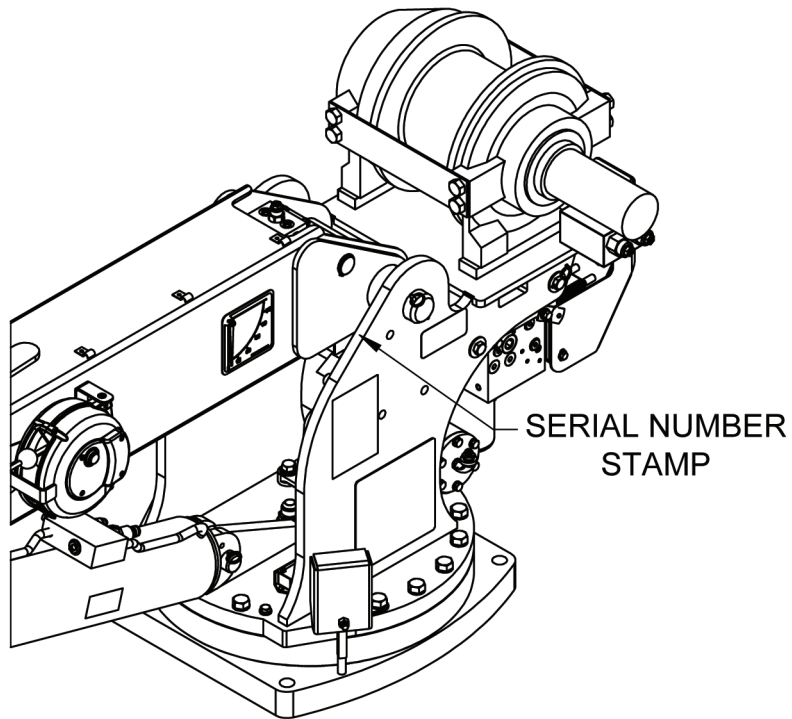

Installation

Recommended Operating Temperature

1. In applications where low oil temperatures may exist (below -20° F), an external heating system may be required.
2. A symptom of excessively low oil temperatures is hydraulic pump/PTO operation but no fluid flow from tank.



Hydraulic reservoir oil temperatures must not exceed 180° F or damage to crane may occur. This may affect crane warranty.

OIL TEMPERATURE

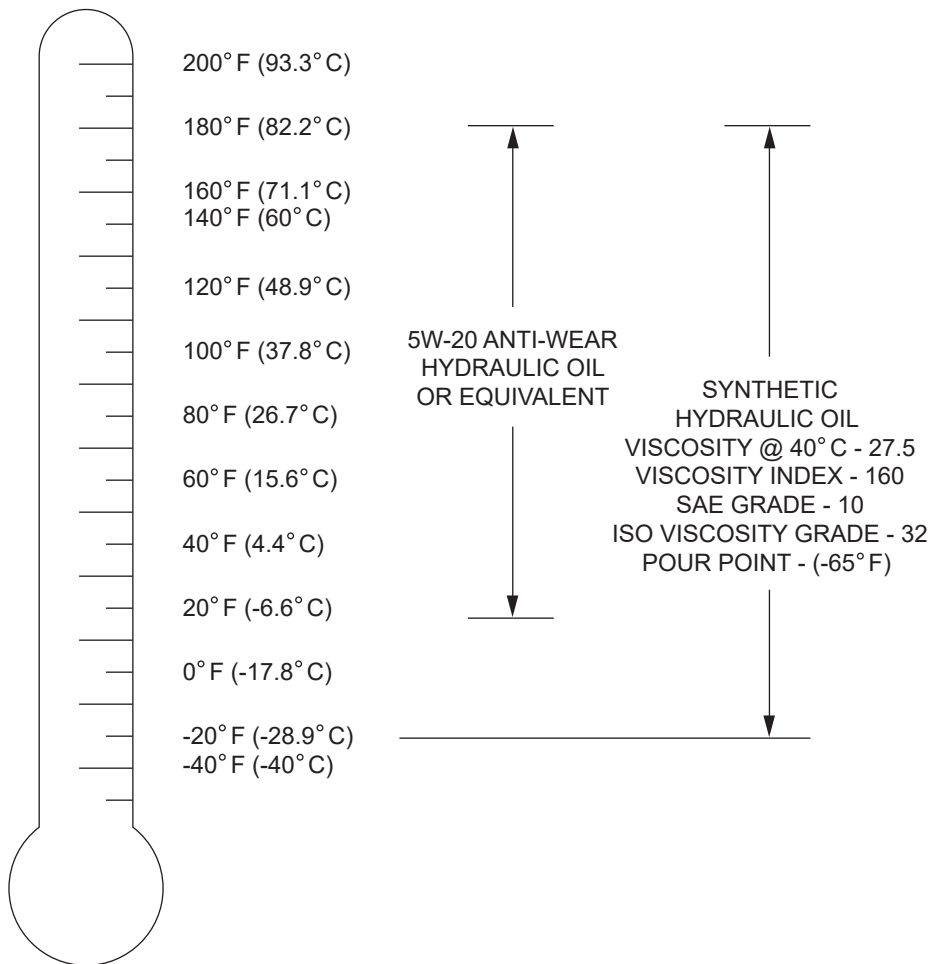

Decal Layout - P/N 366800030

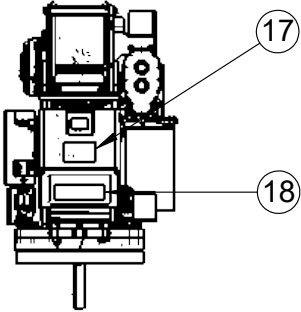
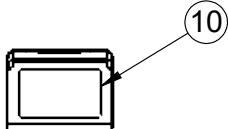
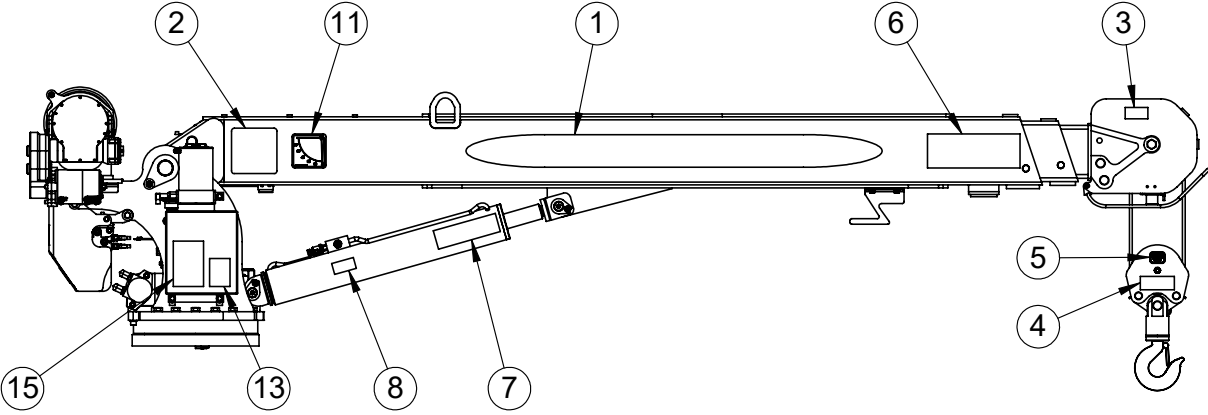
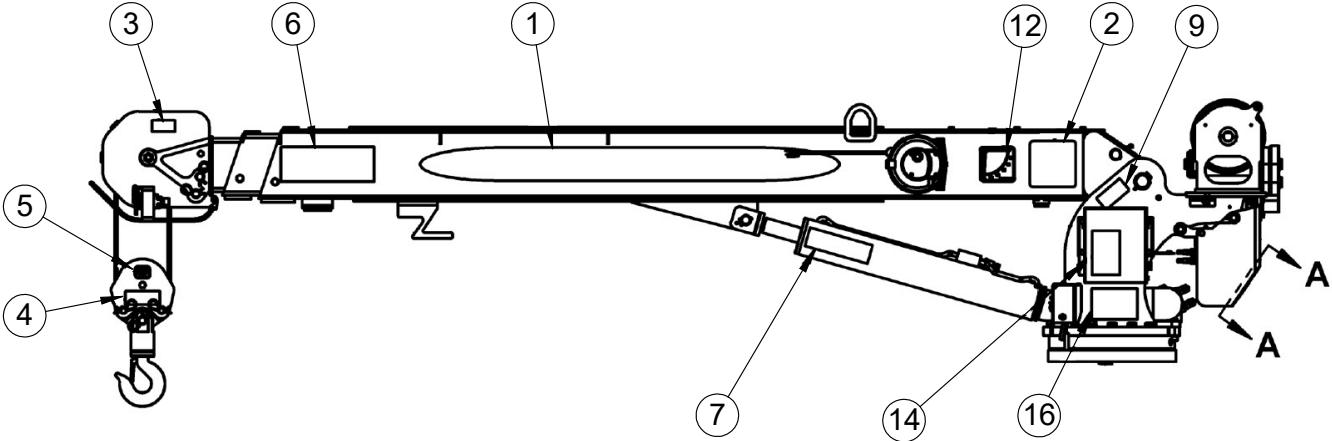

Decal Layout - P/N 366800030

ITEM NO.	QTY	PART NUMBER	DESCRIPTION
1	2	366800035	DECAL, BOOM, EHC-6, NEXSTAR
2	2	366800224	DECAL, LOAD CHART, EHC-6
3	2	040517000	DECAL STAY CLEAR OF BOOM
4	2	040518000	DECAL STAY CLEAR OF LOAD
5	2	366063100	DECAL, TRAVELING BLOCK 6006H
6	2	040529000	DECAL DANGER "ELECTROCUTION HAZARD" POWER LINE
7	2	040519000	DECAL DANGER SCISSOR POINT
8	1	040587000	DECAL WARNING LOAD SENSOR
9	1	330622000	DECAL, SERIAL NO.
10	1	366800208	DECAL, MANUAL OVERRIDE PROCEDURES, GS HYDRAULICS, LARGE EH CRANES
11	1	320318000	DECAL ANGLE INDICATOR CS
12	1	320318001	DECAL ANGLE INDICATOR SS
13	1	040632000	DECAL WARNING - OVERLOAD
14	1	040579000	DECAL OPERATION INSTRUCTIONS
15	1	040580000	DECAL TRAINED OPERATOR
16	1	460169000	DECAL WARNING, REMOTE CONTROL
17	1	040824000	DECAL, AMERICAN FLAG, MADE IN THE U.S.A.
18	1	360034000	DECAL AUTO CRANE LOGO

General Assembly - P/N 366664003

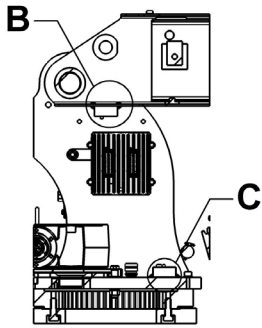
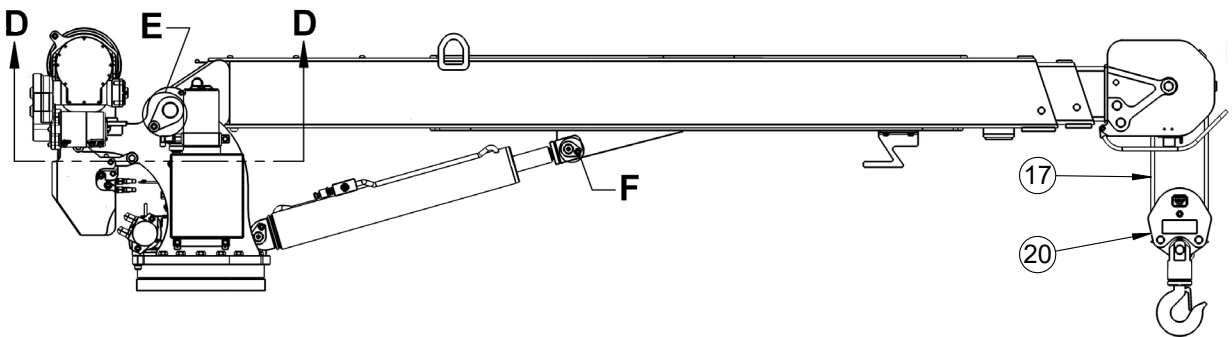
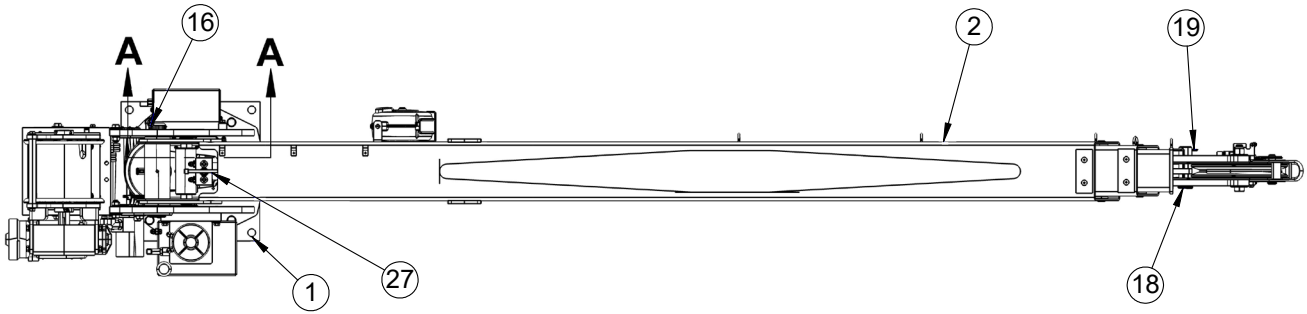

SECTION A-A

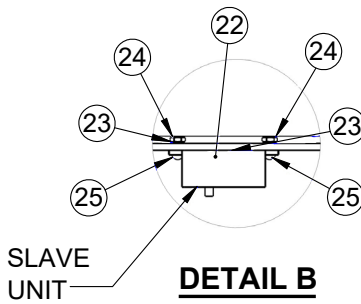

DETAIL B

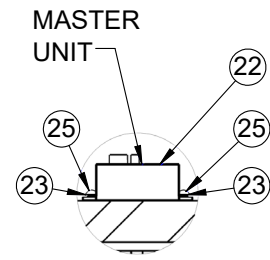

DETAIL C

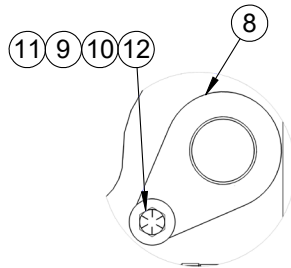

DETAIL E

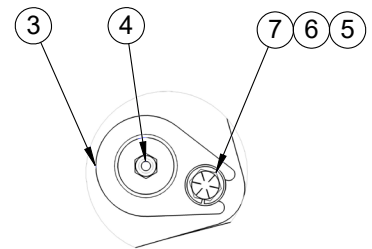

DETAIL F

General Assembly - P/N 366664003

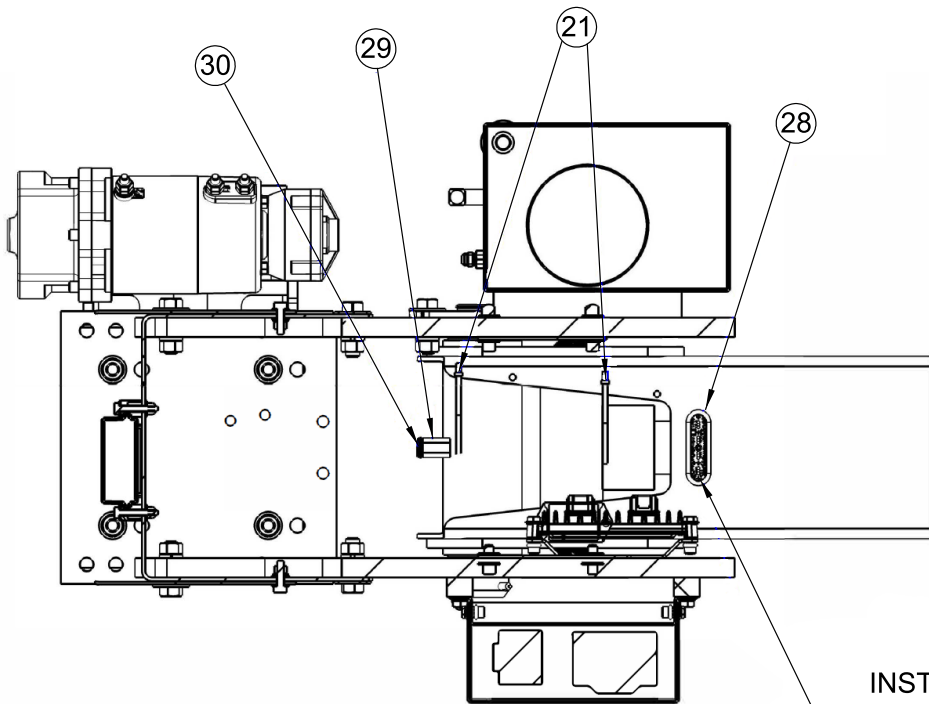

SECTION D-D

INSTALL 366823238 PIGTAIL THROUGH HOLE. INSTALL 320931001 AND 320931002 PER SECTION G-G. FASTEN PIGTAIL TO BOOM WITH 772043000

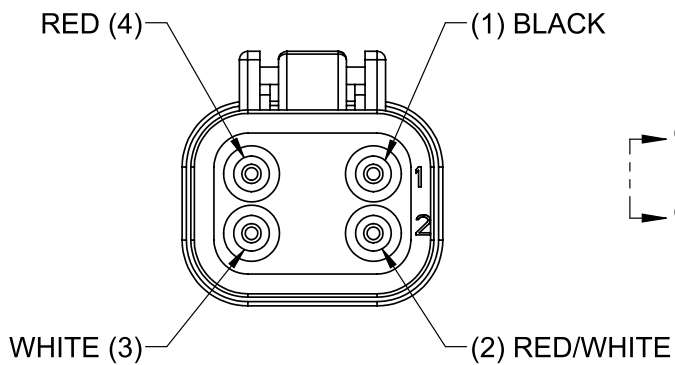

SECTION G-G

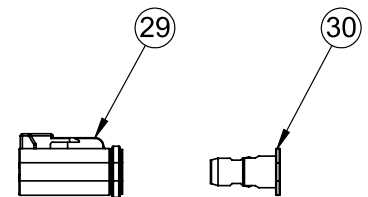

General Assembly - P/N 366664003

ITEM NO.	QTY	PART NUMBER	DESCRIPTION
1	1	366664050	PEDESTAL ASSEMBLY, EHC-6, NEXSTAR
2	1	480988101	BOOM ASSEMBLY (EHC-6 THRU HC-9)
3	1	360676000	PIN, CYLINDER
4	1	239300000	ZERK, GREASE
5	1	320976000	WASHER, FLAT, 3/8 SAE HARDENED
6	1	021100000	WASHER SP LK 3/8
7	1	366159000	SCREW HX HD 3/8-16UNC X 1 1/2 LG GR8
8	1	480988020	PIN, PIVOT, 8406H
9	1	021500000	WASHER, SP LK 1/2
10	1	021600000	WASHER FL 1/2
11	1	017701000	NUT HX 1/2-13UNC
12	1	738642000	SCREW HX HD 1/2-13UNC X 1 3/4 LG GR8
13	1	366664020	SHIP KIT, EHC-6, NEXSTAR
14	1	366800030	DECAL LAYOUT, EHC-6, NEXSTAR
15	1	360678000	PIN, 3/16 COTTERLESS RING
16	1	360677000	PIN, 1/4 COTTERLESS RING
17	1	480031000	WIRE ROPE ASSEMBLY 3/8"
18	1	470076000	PIN, 1 DIA 4-11/16 LG
19	1	360124000	PIN HITCH
20	1	366066000	TRAVELING BLOCK ASSY LESS 2-BLOCK BAR 6006EH
21	2	772043000	ZIP TIE STRAP, 12 IN, NYLON, BLACK
22	1	366823254	SENSOR, TRI-AXIS
23	4	019700000	WASHER SP LK #8
24	2	015500000	NUT HX #8-32UNC CP
25	4	001302000	SCREW RD HD #8-32UNC X 1/2 LG
26	1	330622000	DECAL, SERIAL NO.
27	1	663300001	CABLE TIE, 18"
28	1	366823238	LIGHT, LED 3 INCH (RED, AMBER, GREEN)
29	1	320931001	HOUSING, DEUTSCH PLUG 4-PIN DT06-4S
30	1	320931002	WEDGE, DEUTSCH 4-PIN W4S

Pedestal Assembly - P/N 366664050

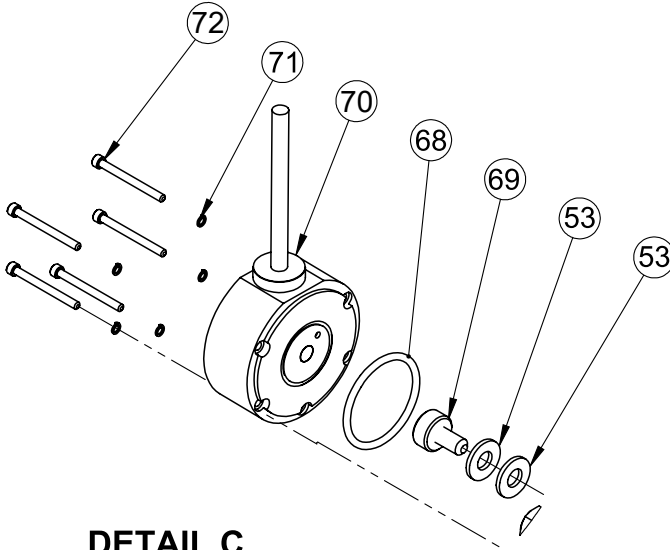

DETAIL C

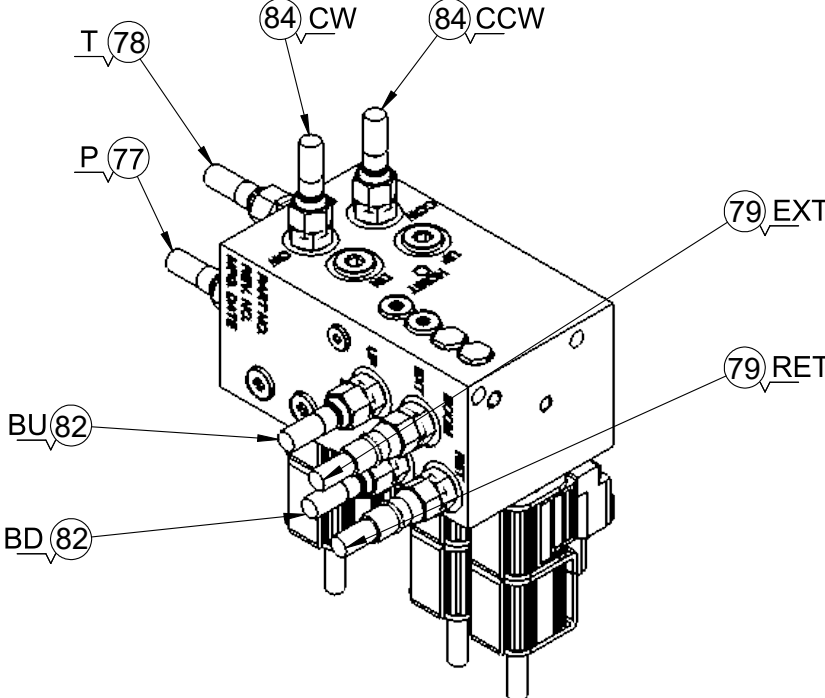

HOSING DETAIL

Pedestal Assembly - P/N 366664050

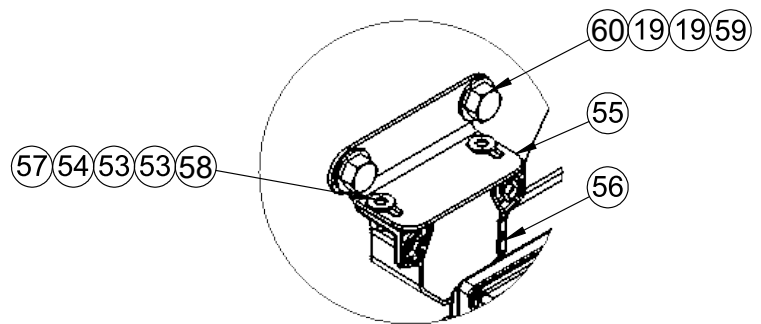
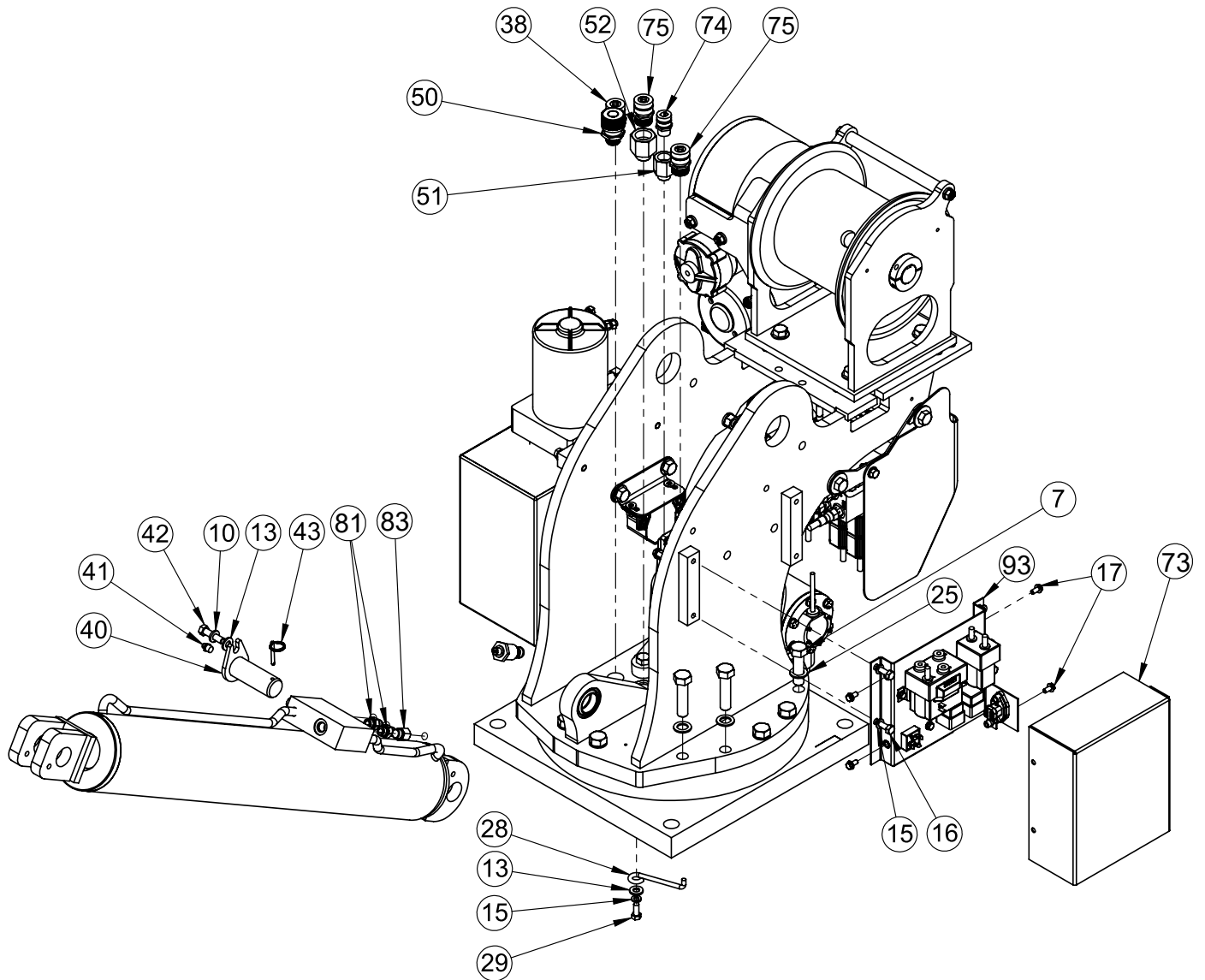

HORN DETAIL

Pedestal Assembly - P/N 366664050

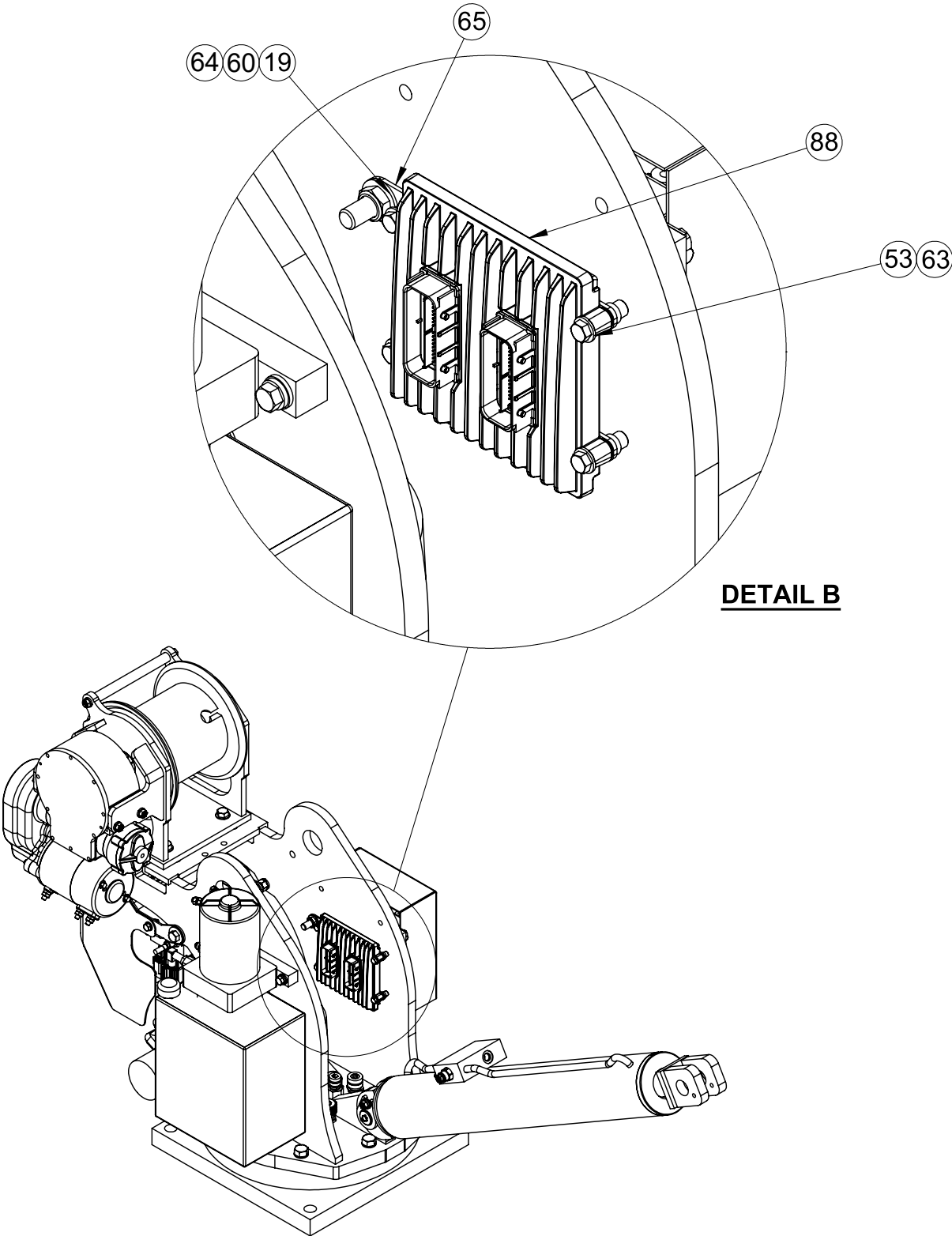

DETAIL B

Pedestal Assembly - P/N 366664050

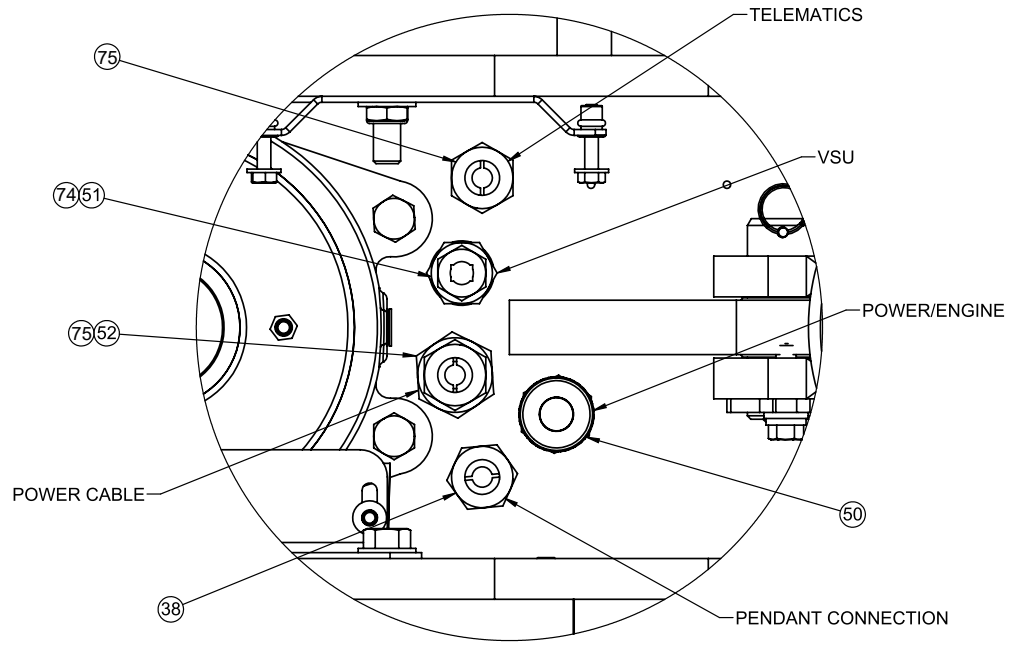

DETAIL D

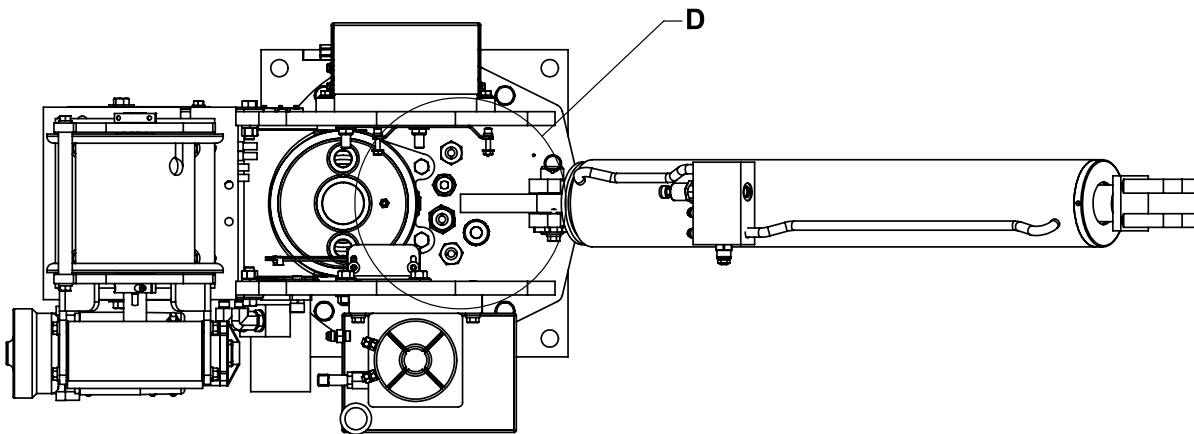

Pedestal Assembly - P/N 366664050

ITEM NO.	QTY	PART NUMBER	DESCRIPTION
1	1	366429000	BASE PLATE
2	1	360646060	PEDESTAL WELDMENT, LARGE EH CRANES
3	1	480023002	BEARING ROTATION 5005-8005
4	36	023902000	WASHER FL 5/8 HARDENED
5	24	012198000	SCREW HX HD 5/8-11UNC X 1 3/4 LG GR8
6	2	366393000	SCREW HX HD 5/8-11UNC X 2 1/2 LG GR8
7	10	490171000	SCREW HX HD 5/8-11UNC X 2 1/4 LG GR8
8	4	006205000	SCREW SOC HD 5/8-11UNC X 1 1/4 LG
9	1	366651000	BAR, POWER UNIT MOUNT
10	7	021100000	WASHER SP LK 3/8
11	2	008702000	SCREW HX HD 3/8-16UNC X 1 1/4 LG GR5
12	1	366650000	HYDRAULIC POWER UNIT
13	6	320976000	WASHER, FLAT, 3/8 SAE HARDENED
14	4	009116000	SCREW HX HD 3/8-16UNC X 2 GR5
15	5	020601000	WASHER SP LK 5/16
16	4	007400000	SCREW HX HD 5/16-18UNC X 1 LG GR5
17	4	360493000	SCREW HX WHIZ-LK 1/4-20UNC X 1/2 LG
18	1	113001000	HOIST, DCG24-246R W/ FRAME
19	16	320588000	WASHER, FL 1/2, HARDENED
20	12	021500000	WASHER, SP LK 1/2
21	8	017701000	NUT HX 1/2-13UNC
22	4	011608000	SCREW HX HD 1/2-13UNC X 2 LG
23	1	480011000	SEAL ROTATION BOX
24	2	017704000	NUT HX HVY 1/2-20UNF
25	2	009118000	SCREW SOC HD 1/2-13UNC X 2 LG
26	2	011202000	SCREW HX HD 1/2-20UNF X 2 3/4 LG GR5
27	1	360162000	RING, ECCENTRIC, 5 IN DIA
28	1	360207000	RETAINER ECCENTRIC RING
29	1	007807000	SCREW HX HD 5/16-18UNC X 3/4 LG GR5
30	1	366440000	ROTATION MOTOR
31	2	021502000	WASHER SP LK 1/2 HI COLLAR
32	2	012197000	SCREW SOC HD 1/2-13UNC X 1/2 LG
33	4	011603000	SCREW HX HD 1/2-13UNC X 1 3/4 LG
34	1	360646075	HARNESS, ELECTRICAL, LARGE EH CRANES, NEXSTAR
35	4	002614000	SCREW HX HD 5/16UNC X 5/8 CP GR3 SELF TAP
36	1	360646077	BRACKET VALVE BLOCK AND RECEIVER, NEXSTAR
37	1	366333000	BEARING, SPHERICAL 1.25 ID

Pedestal Assembly - P/N 366664050

ITEM NO.	QTY	PART NUMBER	DESCRIPTION
38	1	366698011	CORD GRIP, .38"-.50" GRIP, 3/4" HUB, F3
39	1	366822250	CYLINDER, LIFT, 6406H, STROKE - 27.81
40	1	360676000	PIN, CYLINDER
41	1	239300000	ZERK, GREASE
42	1	366159000	SCREW HX HD 3/8-16UNC X 1 1/2 LG GR8
43	1	360678000	PIN, 3/16 COTTERLESS RING
44	1	360646074	COVER, VALVE
45	4	021600000	WASHER FL 1/2
46	4	020901000	WASHER FL 5/16
47	2	020600000	WASHER 5/16 LOCK SS
48	2	016500000	NUT HX 5/16-18UNC
49	2	007811000	SCREW HX HD 5/16-18UNC X 1 LG GR5
50	1	366823447	CORD GRIP, 1/2 NPT, FOR CORD OD 0.63"-0.72", ALUMINUM
51	1	366800209	PORT ADAPTER, STRAIGHT, -8 MALE SAE-ORB TO 1/2 NPTF
52	1	366800210	PORT ADAPTER, STRAIGHT, -10 MALE SAE-ORB TO 3/4 NPTF
53	14	020400000	WASHER FL SAE 1/4
54	2	020200000	WASHER SP LK 1/4
55	1	366823224	BRACKET, ALARM, HC-6 TO HC-10
56	1	366823223	KIT, ALARM, CONSTANT TONE, W/ DEUTSCH PLUG
57	2	015900000	NUT HX 1/4-20UNC SS
58	2	005500000	SCREW HX HD 1/4-20UNC X 3/4 LG
59	2	738058008	NUT HX 1/2-13UNC
60	4	010201000	SCREW HX HD 1/2-13UNC x 1 1/2 LG
61	1	366800253	TAG, ID, EHC-6
62	1	160247000	SPEED REDUCER-SH400R,SPC,ROT BX,A/C, W/ ROTARY ENCODER
63	4	006200000	SCREW HX HD 1/4-20UNC X 1 1/4 LG
64	2	605001257	NUT, THIN, NYLON LOCK, 1/2-13
65	1	366823428	ASSEMBLY, BRACKET, CONTROLLER, NEXSTAR, HC-5,6,7,8,9,10,12S
66	2	005804000	SCREW HX HD 1/4-20UNC X 1-1/2 LG
67	2	016300000	NUT HX NYLK 1/4-20UNC
68	1	366823448	O-RING, -125, 1-1/2 OD, 1-5/16 ID, 3/32 THICK, BUNA-N
69	1	366823444	MAGNET, ROTARY SENSOR, 1/4-20 THREADS, 1/2" LONG
70	1	366823417	SENSOR, ROTARY, QUADRATURE
71	5	366823432	WASHER, SPLIT LOCK, #4, STAINLESS STEEL
72	5	366823425	SCREW, SOCKET HEAD, #4-40 X 1.25, PARTIALLY THREADED, STAINLESS STEEL
73	1	366800218	COVER, RELAY PANEL

Pedestal Assembly - P/N 366664050

ITEM NO.	QTY	PART NUMBER	DESCRIPTION
74	1	366694000	CORD GRIP .1875-.25 1/2 HUB
75	2	366698010	CORD GRIP .25-.38 3/4" HUB
76	1	366800221	KIT, HOSE, LARGE EH CRANES, NEXSTAR
77	1	812203018	HOSE ASSY 6 STR
78	1	812203019	HOSE ASSY 6 STR
79	2	812203024	HOSE ASSY 6 JICF STR
80	1	330645000	FITTING 90 6-SAE/6-JIC LONG
81	3	200876000	FITTING STR 6 SAE/6 JIC
82	2	812203033	HOSE ASSY -6 X 33" LG.
83	1	369611000	ADAPTER, STR -6 ORM/ -4 ORF
84	2	812209019	HOSE ASSY, -6 HOSE, -6 JICF / -6 JICF 90DEG SHORT, 19" LONG
85	2	490198000	FITTING 90 10 SAE/6 JIC
86	52	374086000	NYLON HOSE SLEEVE, 1.81" ID, 5" LONG
87	1	360646070	KIT, ELEC/HYD LARGE EH CRANES NEXSTAR
88	1	366823402	CONTROLLER, NEXSTAR
89	1	366800205	VALVE BLOCK, LARGE EH CRANE, NEXSTAR
90	1	366823403	BASE STATION, NEXSTAR
91	1	366823409	TRANSDUCER, PRESSURE, 0-4000 PSI
92	1	360646071	KIT, ELECTRICAL, LARGE EH CRANES, NEXSTAR
93	1	360646072	RELAY PANEL ASSEMBLY, LARGE EH CRANES NEXSTAR
94	1	680160000	CABLE ASSY, 4 GA, GROUND 72in LG
95	1	366509001	COND ASS'Y 4GA, 15LG, 3/8-5/16 W/BOOT
96	1	366509000	GROUND WIRE ASSY

Hydraulic Valve Bank - P/N 366800205

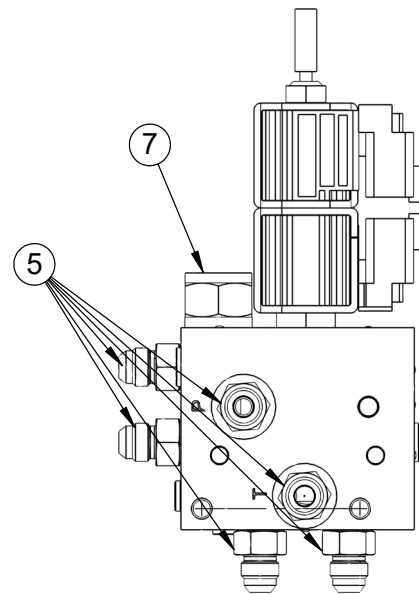
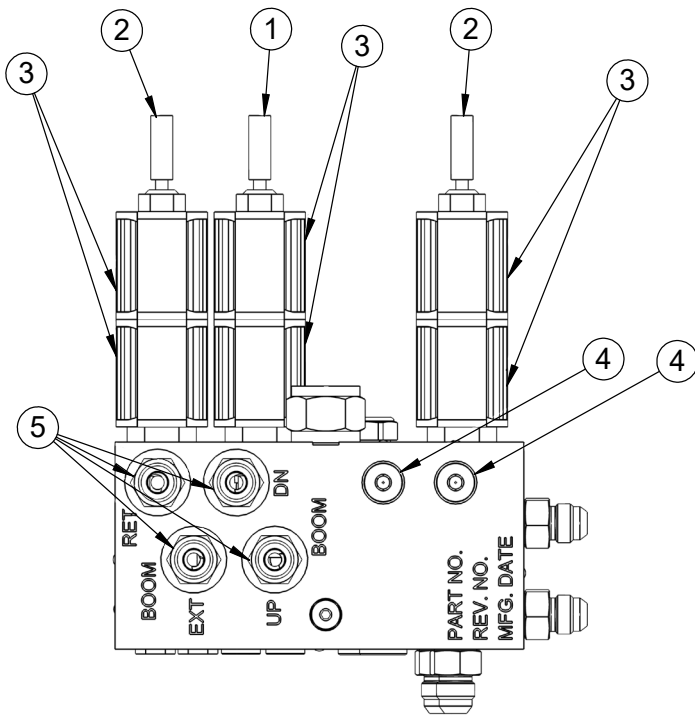
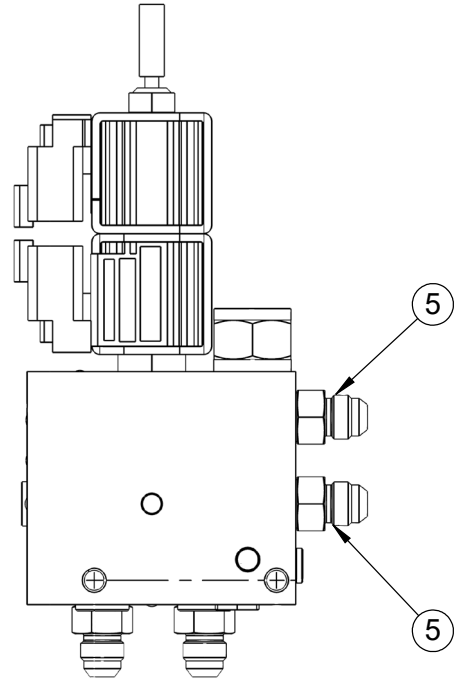
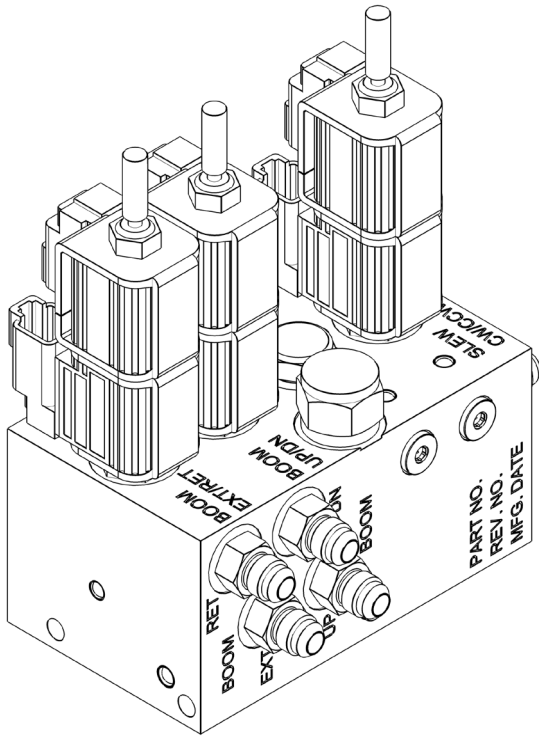

Hydraulic Valve Bank - P/N 366800205

ITEM NO.	QTY	PART NUMBER	DESCRIPTION
1	1	320991918	VALVE, CARTRIDGE PROPORTIONAL 3203/4004 NEXSTAR, FLOATING CENTER, 5 GPM
2	2	320991912	VALVE, CARTRIDGE PROPORTIONAL[]3203/4004 NEXSTAR CLOSED CENTER
3	6	320991901	COIL, SOLENOID 12VDC 1/2" DIA
4	6	320991905	VALVE, CHECK SIZE 04
5	8	200876000	FITTING STR 6 SAE/6 JIC
6	1	320991904	ORIFICE, 1/4-20UNC 3/8LG 0.018 DIA
7	1	320991903	VALVE, LOGIC

Wiring Harness - P/N 360646075

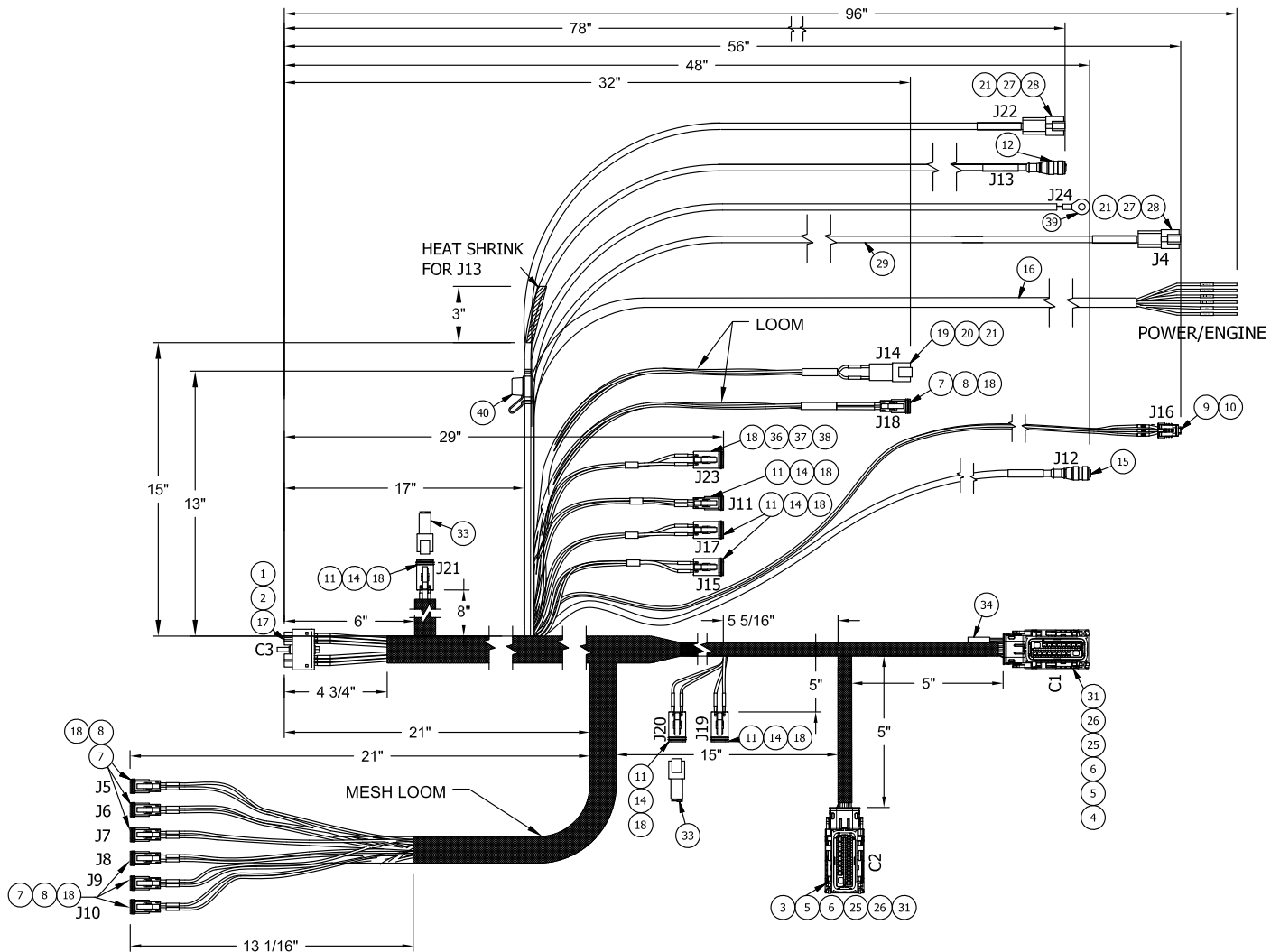

CONNECTOR ID			
CONNECTOR	DESCRIPTION	CONNECTOR	DESCRIPTION
C1	MC43 CONNECTOR C1	J14	ALARM LIGHT
C2	MC43 CONNECTOR C2	J15	ADDRESS
C3	BASE STATION	J16	BOOM PT
J4	TELEMATICS	J17	ROTATE LIMIT SWITCHES
J5	BOOM DOWN	J18	HORN
J6	BOOM UP	J19	ROTARY SENSOR
J7	ROTATE CW	J20	OIL TEMPERATURE SENSOR
J8	ROTATE CCW	J21	G11 MODEM
J9	BOOM RETRACT	J22	VSU
J10	BOOM EXTEND	J23	RELAY PANEL
J11	ANTI-2 BLOCK	J24	GROUND
J12	BOOM ANGLE SENSOR	PWR/ENG	POWER/ENGINE
J13	PENDANT CONNECTION	-	-

Hoist Assembly - P/N 113001

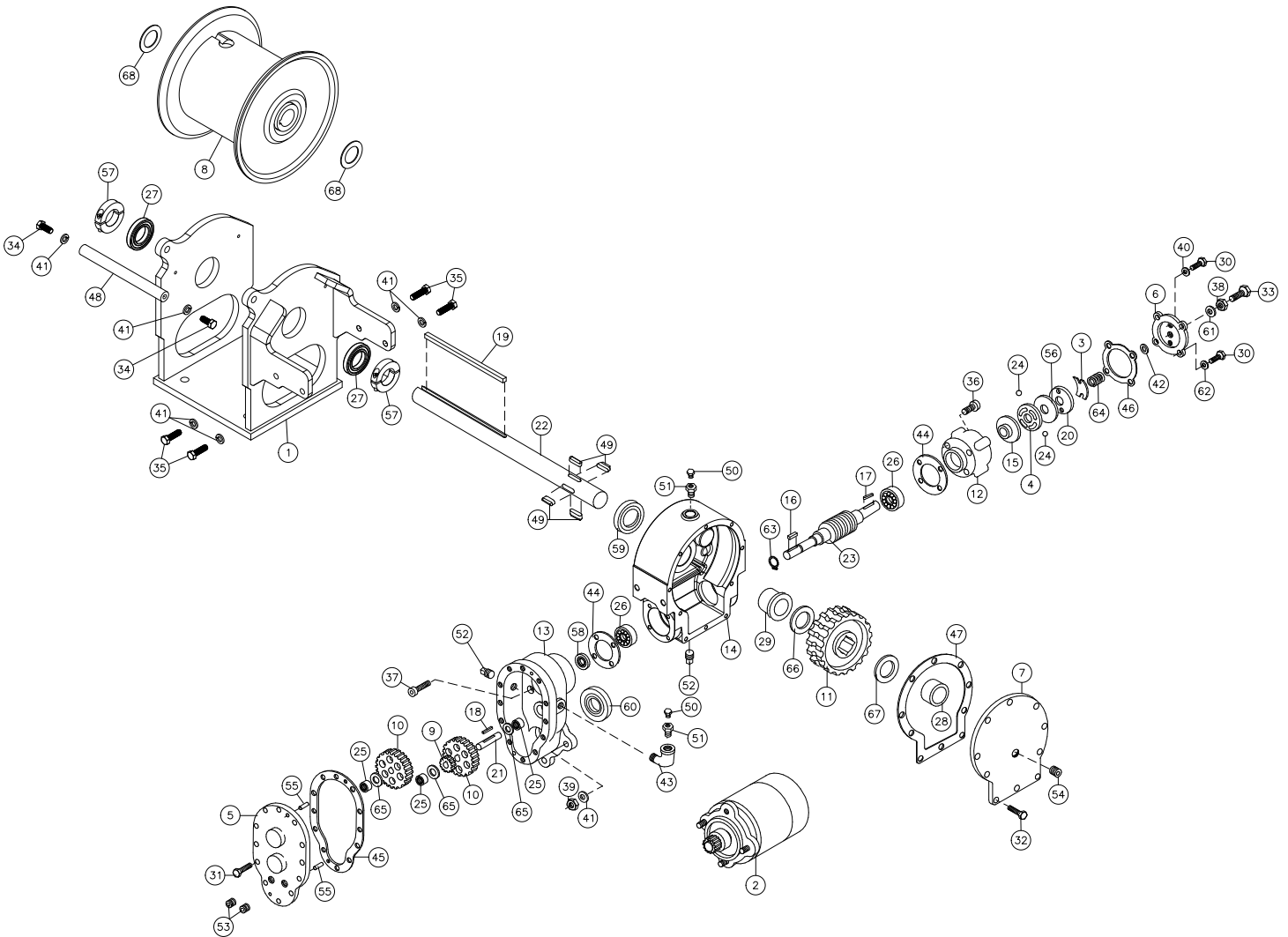

ITEM NO.	QTY	PART NUMBER	DESCRIPTION
1	1	242177000	WELDMENT-FRAME
2	1	262036000	24V, ELECTRIC MOTOR ASSEMBLY
3	1	306034000	SPRING-FLAT
4	1	314008000	CAM PLATE
5	1	328106000	COVER-SPUR GEAR HOUSING
6	1	328128000	COVER-WORM BRAKE
7	1	328134000	GEAR HOUSING COVER
8	1	332210000	DRUM
9	1	334001000	IDLER GEAR
10	2	334003000	GEAR-INTERMEDIATE
11	1	334163000	GEAR

Hoist Assembly - P/N 113001

ITEM NO.	QTY	PART NUMBER	DESCRIPTION
12	1	338007000	BRAKE HOUSING
13	1	338203000	SPUR GEAR HOUSING
14	1	338273000	GEAR HOUSING
15	1	340002000	BRAKE HUB
16	1	342023000	KEY-SQ ENDS, 3/16 X 3/16 X 1/2 LG
17	1	342027000	KEY-RD ENDS, 3/16 X 3/16 X 1LG
18	1	342033000	KEY-SQ ENDS, 3/16 X 3/16 X 1-7/16LG
19	1	342199000	KEY-SQUARE, 5/16 X 7-1/2 LONG
20	1	352022000	RETAINER PLATE
21	1	356901000	SHAFT-3/4 X 2-13/16LG
22	1	357145000	OUTPUT SHAFT
23	1	368022000	WORM
24	2	400003000	BALL-POPPET 3/8 O.D.
25	3	402001000	NEEDLE BEARING
26	2	402002000	BALL BEARING
27	2	402128000	BEARING-BALL, 1-1/4 I.D.
28	1	412044000	BUSHING
29	1	412045000	BUSHING
30	6	414021000	BOLT-1/4NCX1, HXD, G8, ALLTHD, HV/P, Z/P
31	12	414038000	CAPSCREW-1/4-20NCX3/4, HXHD, GR-5, Z/P
32	10	414045000	CAPSCREW-1/4-20NCX7/8 LG. HEX HD, GR 5, Z/P
33	1	414224000	BOLT-3/8-16NCX1 1/2, HX, G5, AL-TH, Z/P
34	2	414294000	CAPSCREW-3/8-16NC X 7/8 LG, HX HD, GR5, Z/P
35	4	414316000	CAPSCREW-3/8-16NCX1 1/4, HXHD, Z/P, G5
36	4	414821000	CAPSCREW-1/4-20NC X7/8, HXSOCBUTTHD
37	4	414845000	CAPSCREW-1/4-20NC X1, HXSOCHD, NYLOK
38	1	418036000	NUT-3/8-16 NC, HEX JAM, Z/P
39	3	418040000	NUT-3/8-24NF HEX REG Z/P
40	2	418154000	WASHER-1/4 FLAT ALUM.
41	9	418177000	LOCKWASHER-3/8 MED SECT, Z/P
42	1	418181000	WASHER-3/8 ID SAE FLAT,Z/P
43	1	432011000	ELBOW-90DEG, STREET, 3/8NPT, Z/P
44	2	442184000	GASKET-BEARING CAP
45	1	442185000	GASKET-SPUR GEAR BOX
46	1	442189000	GASKET-BRAKE HOUSING COVER
47	1	442205000	GASKET-GEAR HOUSING COVER
48	1	448100000	TIE BAR

Hoist Assembly - P/N 113001

ITEM NO.	QTY	PART NUMBER	DESCRIPTION
49	4	450016000	KEY-BARTH, 5/16 X 15/16LONG
50	2	456008000	RELIEF FIT-1/8-27PFT
51	2	468002000	RED-3/8-1/8NPTF
52	2	468011000	PIPE PLUG-3/8-18NPTF, 7/16 SQ HD, Z/P
53	2	468017000	PIPE PLUG-1/4-18NPTF, HEX SOC HD, Z/P
54	1	468018000	PIPE PLUG-3/8-18NPTF HXSOCHD-LES, Z/P
55	2	470001000	DOWEL PIN-3/16 DIA X 3/4 LG
56	1	474001000	PLATE-THRUST
57	2	479016000	COLLAR-SPLIT, 1-1/4 I.D.
58	1	486009000	OIL SEAL
59	1	486017000	OIL SEAL
60	1	486023000	SHAFT, SEAL
61	1	486069000	SEAL-3/8
62	4	486070000	SEAL
63	1	490003000	SNAP RING
64	1	494007000	SPRING
65	3	518002000	THRUST WASHER
66	1	518015000	THRUST WASH
67	1	518040000	THRUST WASHER-1/8 THICK
68	2	518063000	BEARING-BRONZE

Rotation Gearbox - P/N 160247

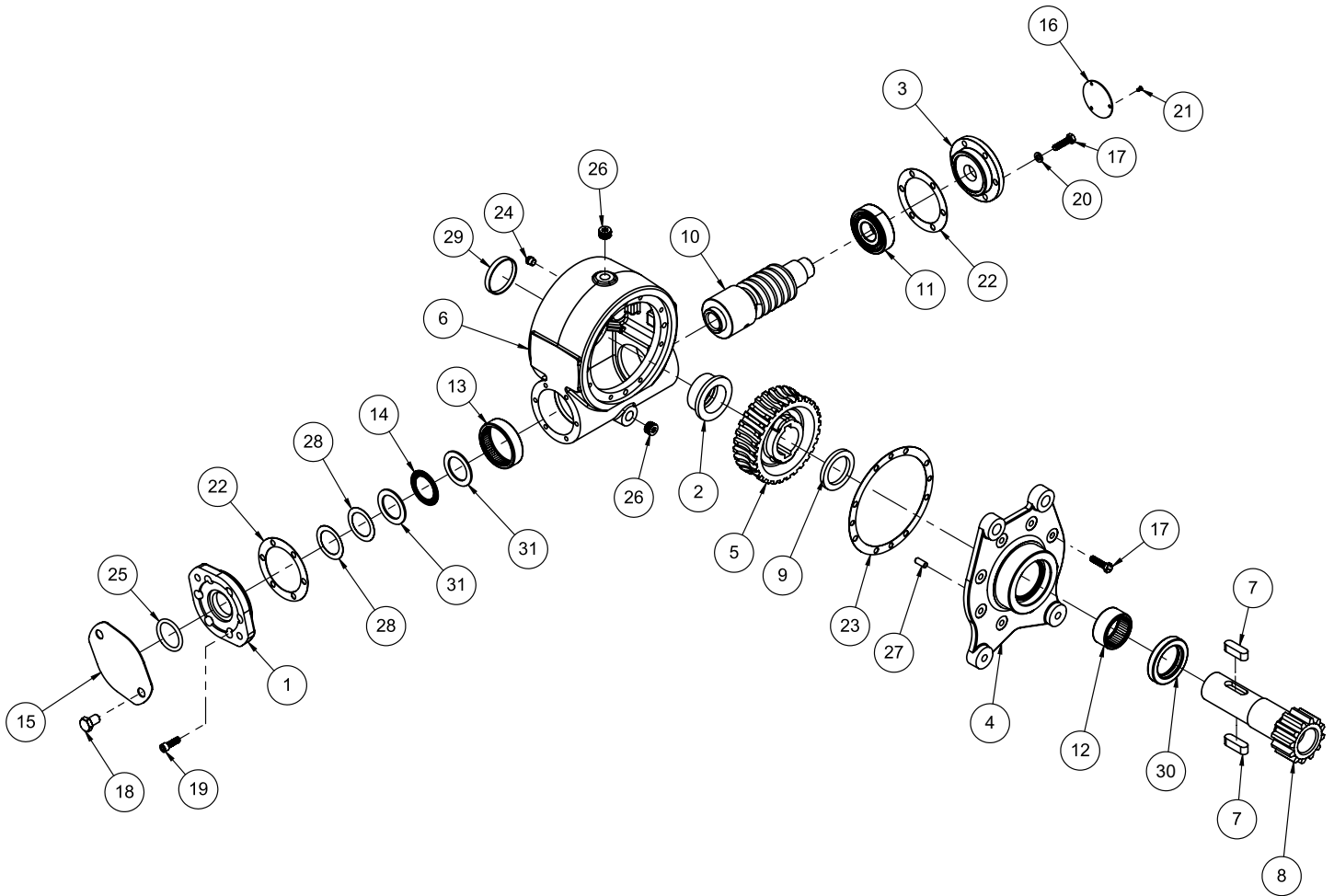

Rotation Gearbox - P/N 160247

ITEM NO.	QTY	PART NUMBER	DESCRIPTION
1	1	300058000	ADAPTER-MOTOR SH-400R ROTATION BOX AUTO CRANE
2	1	308085000	BUSHING
3	1	316114000	CAP-BEARING REATINER, AUTOCRANE ENCODER
4	1	328126000	COVER
5	1	334016000	GEAR-WORM
6	1	338261000	GEAR HOUSING
7	2	342120000	KEY-SHAFT
8	1	357139000	OUTPUT PINION -AUTOCRANE ROTATION BOX
9	1	366019000	THRUST WASHER, AUTOCRANE ROTATION BOX
10	1	368219000	WORM-RH, SINGLE LEAD, SH400 ROTATION BOX FOR AUTOCRANE W/ ENCODER MAGNET MOUNTING
11	1	402044000	BEARING, ANGULAR CONTACT, 7306
12	1	402105000	BEARING-NEEDLE, DRWN CUP, TORR#B-3016
13	1	402106000	BEARING-NEEDLE, TORRINGTON #NB-4012
14	1	402107000	BEARING - THRUST, TORRINGTON #NTA2435
15	1	413013000	COVER PLATE
16	1	413145000	COVER PLATE 2.35
17	14	414143000	CAPSCREW, 5/16"-18 X 1-1/4" LG., GRADE 5, BLACK FINISH
18	2	414581000	CAPSCREW-1 /2-13NC X 3/4 LG HX HD GR5 Z/P
19	6	414869000	SCREW-5/16-18NCX 1LG, HXSOC, ND STRIP
20	6	418163000	LOCKWASHER-5/16 MED SECT ZJP
21	3	420051000	SCREW-#4-40 X 1/4" LONG
22	2	442182000	GASKET-BRG RETAINER
23	1	442187000	GASKET-GEAR HOUSING COVER
24	1	456008000	FITTING-RELIEF1/8-27NPTF, 15 PSI MAX
25	1	462029000	O-RING,1 5/8 ID X 2 OD X 3/16 THK
26	2	468018000	PIPE PLUG
27	4	470062000	DOWEL PIN - 5/16 X 3/4 LG
28	2	470166000	SHIM, ROUND, STAINLESS STEEL, 1.5 I.D. X 2.125 O.D. X .010
29	1	472088000	PLUG-EXPANSION,GEAR HSG
30	1	486071000	SEAL - OIL, 1 718 X .468 THK, NAT#450082
31	2	518104000	THRUST WASHER

Boom Assembly - 480988101

ITEM NO.	QTY	PART NUMBER	DESCRIPTION
1	1	480988115	LOWER BOOM WELD (EHC-6 THRU HC-9)
2	1	480988120	MID BOOM WELD, 8406H
3	1	480988130	UPPER BOOM WELD, 8406H
4	1	770055000	FITTING 8 SAE/8 JIC STRAIGHT
5	1	460053000	WEAR PAD, BOTTOM UPPER
6	2	460177160	WEAR PAD, 5.13X3X.25, BOSS 1X3
7	10	360767000	PAD BOOM 1.5 O.D.
8	1	407277000	PAD BOOM 1.5 O.D.
9	1	480988150	CYLINDER, EXTENSION, STROKE - 48/72
10	1	460177161	PIN, 1.25OD, 7.81 GRIP
11	2	480029000	RING RETAINING
12	1	366333000	BEARING, SPHERICAL 1.25 ID
13	2	366394000	BEARING, PIVOT
14	2	460081000	WEAR PAD, CABLE
15	2	460082000	PLATE, WEAR PAD RETAINER
16	4	460177163	SCREW SOC HD CTRSNK 5/16-24UNF X 5/8 LG
17	1	366198000	SHEAVE, ASSEMBLY (3/8)
18	1	014400000	SCREW HX HD 3/4-16UNF X 5 LG GR5
19	2	022102000	WASHER FL 3/4
20	1	018600000	NUT HX NYLK 3/4-16UNF
21	1	646900000	SWITCH, LIMIT ANTI-TWO BLOCK
22	1	642918000	CORD CONNECTOR
23	2	016801000	NUT HX NYLK 5/16-18UNC CP
24	1	470110168	LONG TAB BAIL WELDMENT W/ 2 IN TRIP BAR STAINLESS STEEL
25	2	007807000	SCREW HX HD 5/16-18UNC X 3/4 LG GR5
26	1	366678000	SPRING, EXTENSION
27	2	460177162	SCREW SOC HD 5/8-11UNC X 3/4 LG
28	1	470076000	PIN, 1 DIA 4-11/16 LG
29	4	460177164	SHIM, 1.31 OD X 0.9 ID X 0.04 TH, NYLON
30	1	360124000	PIN HITCH
31	1	374400000	FITTING, -8 ORB, -8 ORB, STRAIGHT
32	1	460177180	VALVE, IN-LINE RELIEF, 400PSI
33	1	366669000	WEAR PAD, BOTTOM MID
34	1	812234017	HOSE ASSY, -8 JICF/-8 JICF, -6 HOSE, 17LG
35	1	239000000	ZERK DRIVE GR
36	1	360759004	CORD REEL ASSEMBLY
37	2	200876000	FITTING STR 6 SAE/6 JIC

Boom Assembly - 480988101

ITEM NO.	QTY	PART NUMBER	DESCRIPTION
38	4	021200000	WASHER FL 3/8
39	1	479200154	OPEN LOAD HOOK, BOLT-ON
40	4	021100000	WASHER SP LK 3/8
41	4	479200169	3/8-24 HHCS, 3/4 LG, ZINC PLATED, GR 5
42	2	016100000	NUT, 1/4-28, ZINC PLATED
43	2	020300000	WASHER FL 1/4
44	2	016100001	SCREW, FLAT HEAD, 1/4-28 X 1, ZINC PLATED, GR 5
45	2	020200000	WASHER SP LK 1/4
46	1	479200152	WEAR PAD, TRAVELING BLOCK

Traveling Block Assembly - P/N 366066000

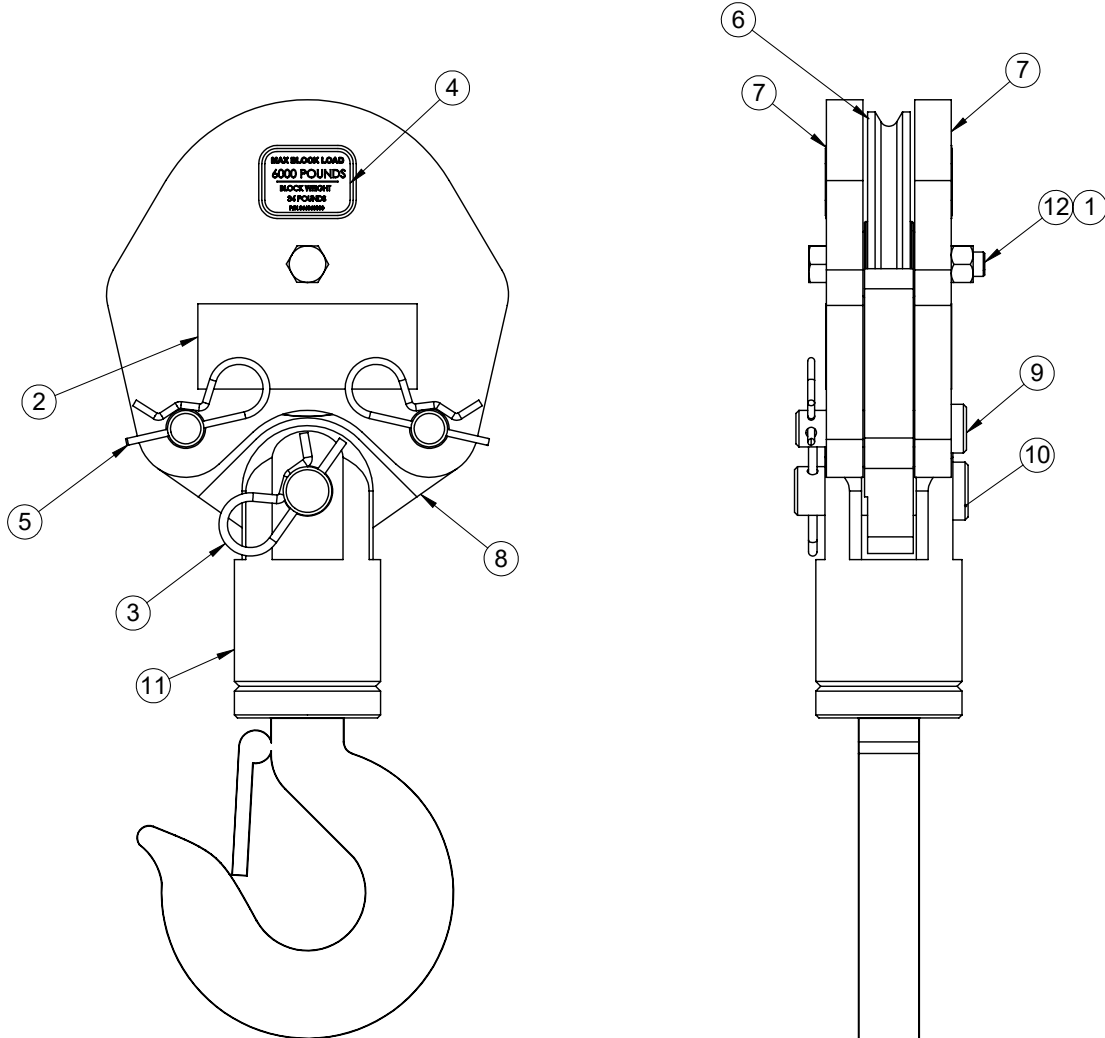

ITEM NO.	QTY	PART NUMBER	DESCRIPTION
1	1	017800000	NUT, HX LK 1/2-20UNF
2	2	040518000	DECAL STAY CLEAR OF LOAD
3	1	360124000	PIN HITCH
4	2	366063100	DECAL, TRAVELING BLOCK 6006H
5	2	366813000	PIN HITCH
6	1	480130000	SHEAVE ASSY
7	2	480363000	SHORT BLOCK SIDE PLATE
8	1	480364000	TACKLE LOWER
9	2	480367000	PIN BLOCK
10	1	480368000	PIN SWIVEL HOOK
11	1	480371000	HOOK SWIVEL 3 METRIC TON
12	1	480372000	SCREW HX HD 1/2UNF X 3 1/4 LG GR 8

Warranty

AUTO CRANE NEW CRANES LIMITED WARRANTY

1.1 **Scope of Warranty Coverage.** Upon the terms and subject to the conditions set forth in this limited warranty:

(a) AUTO CRANE (referred to herein as "**AUTO CRANE**" or the "**Manufacturer**") warrants to each initial end user customer (a "**Purchaser**") of a new crane together with any accessories manufactured and sold directly from AUTO CRANE (the "**Product**") that the Product shall be free from defects in material and workmanship, under normal working and service conditions, for a period of eighteen (18) months from the date the Product is shipped from AUTO CRANE. (the "**Warranty Term**"). A Purchaser shall be eligible for an additional eighteen (18) months of coverage in addition to the Warranty Term (also referred to as the "**Standard (+) PLUS benefit**") only if the Purchaser (i) complies with Section 1.2(a) and (ii) registers the Product during the Warranty Term at myproduct.autocrane.com.

(b) Notwithstanding the foregoing, this warranty does not cover components damaged by accident, abuse, misuse, neglect, untrained operators, collision, overloading, modification, disassembly, rework, misapplication, improper installation, lack of lubrication or maintenance, or improper service. This warranty does not cover the paint or material finish, removal or reinstallation of the crane or components, or normal wear and tear and loss of functionality due to aging of the Product (which may include but is not limited to bearings, bushings, seals, O-rings, gaskets, brake material, motor brushes, electrical cables and more).

1.2 **Eligibility of Warranty Coverage.**

(a) A Purchaser shall be eligible for warranty coverage under this Limited Warranty during the Warranty Term only if:

(i) Prior to placing a Product in service, and throughout use of the Product during the Warranty Term, the Purchaser provides (or causes to be provided) proper storage such that foreign objects (e.g. rain or debris) cannot enter any Product through entry ports which are normally closed during operation.; and

(ii) The Purchaser maintains, or causes to be maintained, the Product according to commercially reasonable standards and utilizes the Product for the purposes for which it was created; and

(iii) No repairs or alterations have been made by any party other than AUTO CRANE, including Purchaser, unless otherwise authorized in writing by AUTO CRANE.

1.3 **Transferability of Warranty.**

(a) This warranty is transferable only from the Purchaser to the first subsequent transferee (the "**Transferee**") of the Product from Purchaser upon (i) written notification to AUTO CRANE and (ii) registration of the transfer, both within 30 days of such Product transfer.

(b) Upon satisfaction of transfer requirements set forth in Section 1.3(a), the Transferee shall succeed to all the rights and obligations of the Purchaser set forth in this Limited Warranty.

1.4 **Certain Limitations on Scope of Warranty Service.**

(a) Any obligation of AUTO CRANE under this warranty, statutory or otherwise, is limited to the repair of the Product, at its factory or Authorized Service Centers. Notwithstanding the foregoing, if field service or repair is performed by AUTO CRANE at the request of the Purchaser and no defect is found with material or workmanship of the Product, the Purchaser shall compensate AUTO CRANE for its time and expenses within thirty (30) days of delivery of an invoice relating to the same. If repair is determined by AUTO CRANE in its sole, absolute and uncontrolled discretion to be impossible or impractical, then AUTO CRANE may satisfy this warranty by replacing the Product. AUTO CRANE will not provide any cash payment or credits for defective materials or workmanship.

(b) Purchaser shall be responsible for any and all freight charges for any Product receiving warranty service under this limited warranty. Any travel time, transportation charges, freight charges, or similar costs incurred by AUTO CRANE in connection with the replacement or repair of defective parts, shall, be the responsibility of the Purchaser. If applicable, AUTO CRANE shall invoice Purchaser for the total amount of such charges within sixty (60) days of fulfilling its duties under this warranty, payable within thirty (30) days of delivery of such invoice. In no event shall AUTO CRANE be liable for bills for service, labor or other expenses that have been incurred by the Purchaser without approval or prior authorization by AUTO CRANE for inspection, maintenance, or repair of the Product.

(c) If a Product is found to be operable upon inspection, the Product, at Purchaser's election, may be either (1) returned to the Purchaser with a service charge from AUTO CRANE for inspection, cleaning, and routine replacement of all rubber components and any other parts that show wear; or (2) AUTO CRANE can dispose of the product safely.

1.5 Limitations of Liability. AUTO CRANE shall in no event be liable for punitive, special or consequential damages relating to the Product or this Warranty. AUTO CRANE makes no warranty in respect to third-party accessories, upgrades, or additions to the Product.

1.6 Improving Product. AUTO CRANE reserves the right to improve the Product through changes in design or materials as it may deem desirable or necessary without being obligated to incorporate, upgrade, or otherwise modify previously manufactured products.

1.7 Limitations of Warranty.

(a) THE WARRANTY SET FORTH ABOVE IS THE ONLY EXPRESS WARRANTY. AUTO CRANE HEREBY DISCLAIMS AND EXCLUDES ANY OTHER EXPRESS, IMPLIED, OR STATUTORY WARRANTIES, ARISING BY OPERATION OF LAW, COURSE OF DEALING, COURSE OF PERFORMANCE, USAGE, OF TRADE, OR OTHERWISE, INCLUDING, WITHOUT LIMITATION, ANY WARRANTIES OF MERCHANTABILITY, FITNESS FOR A PARTICULAR PURPOSE, AND INTELLECTUAL PROPERTY RIGHTS OF A THIRD PARTY.

(b) ANY IMPLIED WARRANTY WHICH BY LAW MAY NOT BE EXCLUDED IS LIMITED IN DURATION TO ONE (1) YEAR FROM THE DATE OF ORIGINAL RETAIL PURCHASE OF THE PRODUCT.

(c) This warranty gives you specific legal rights, and you may also have other rights which vary from jurisdiction to jurisdiction.

(d) This warranty is valid only in the U.S.A. and Canada. For warranty outside the U.S.A. and Canada contact your nearest AUTO CRANE Distributor.

1.8 No Modifications to Warranty. No AUTO CRANE dealer, distributor, agent or employee is authorized to make any modification, extension or addition to this warranty.

1.9 How to Apply for Warranty Coverage.

All claims are handled by contacting your nearest Auto Crane Dealer. For questions, please contact customer support: accustomersupport@ramseyindustries.com.

Visit [Dealer Locator - Auto Crane](#) for Auto Crane Dealer locations and contact information.

Additional warranty, service support, product information, and parts information can be found on www.autocrane.com.

