

WELD: MINIMUM YIELD 36,000 PSI
BODY SHOWN AS REFERENCE

SECTION A-A

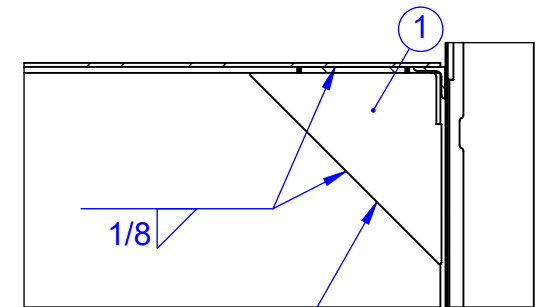

FLUSH WITH BACK OF COMPARTMENT

SECTION C-C

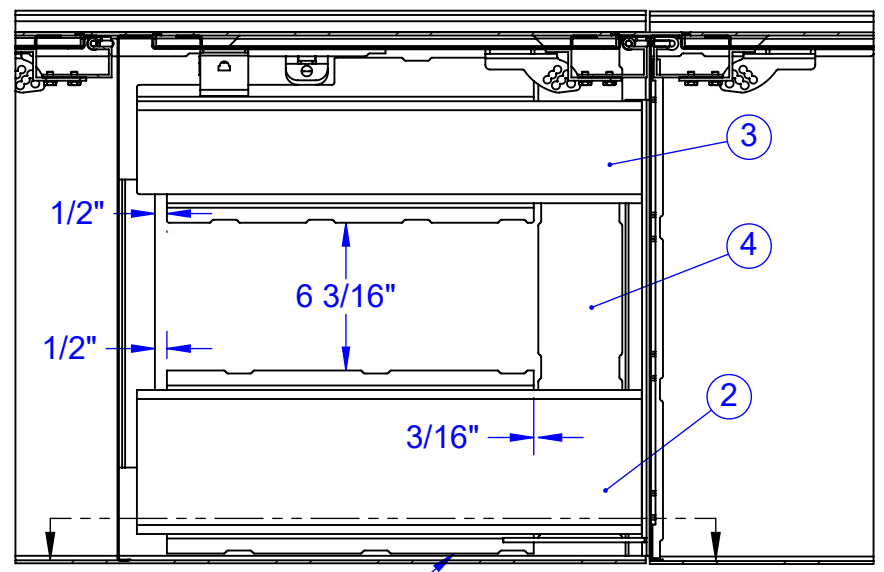
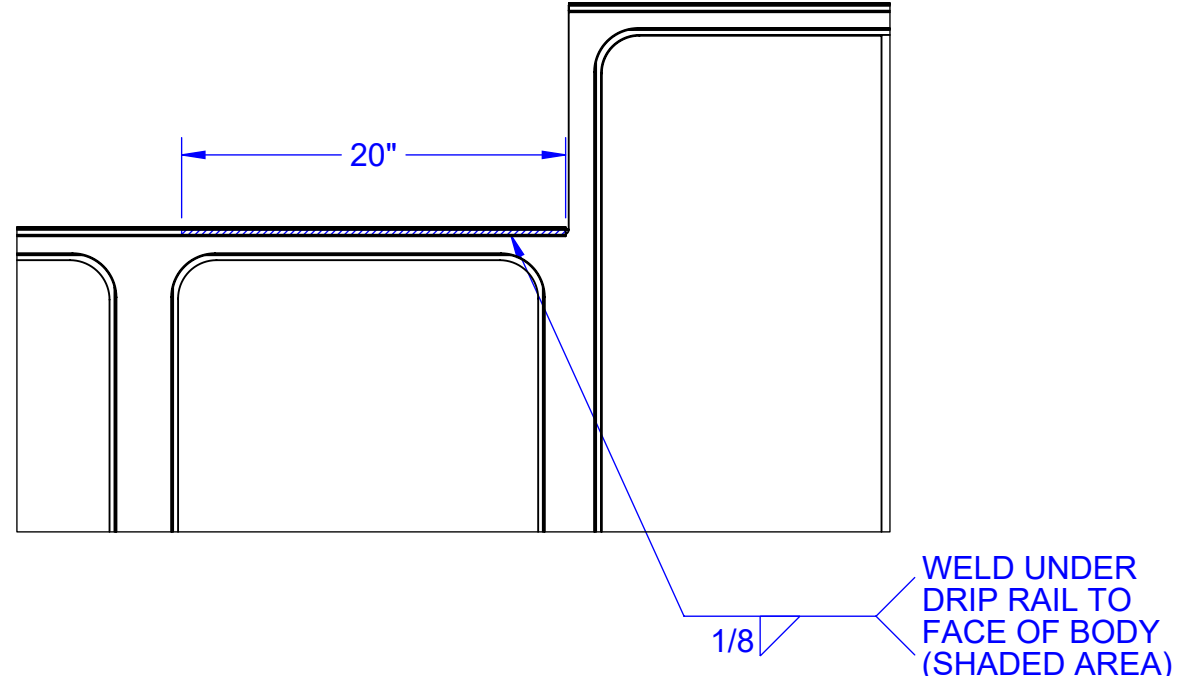

FLUSH WITH BACK OF COMPARTMENT

SECTION B-B

NOTE:
1. INLCUDE 715068048 MANUAL PAGES WITH KIT

NOTES	BOM REVS	ITEM NO.	QTY	PART NUMBER	DESCRIPTION
		1	1	715068006	ANGLE, BOOM SUPPORT REINFORCEMENT
		2	1	715068038	CHANNEL, REINFORCEMENT. T38/84 TALL RETRO
		3	1	715068039	CHANNEL, BOOM SUPPORT REINFORCEMENT W/CUTOUT T38/84 TALL RETRO
		4	1	715068041	PLATE, REINFORCEMENT, 21" X 3", RETRO
		5	1	715068040	PLATE, REINFORCEMENT, 18.5" X 11.5", RETRO
1		6	1	715068048	MANUAL, TITAN 38 84CA REINFORCEMENT, INSTALLATION

700300	A	PRODUCTION RELEASE	1/13/20	CDS
ECN#	REV.	DESCRIPTION	DATE	BY
		REVISIONS		

UNLESS OTHERWISE NOTED ALL DIMENSIONS ARE IN INCHES.
TOLERANCES UNLESS OTHERWISE SPECIFIED:
ANGLES ± 1/2°
FRACTIONAL ± 1/16
REMOVE ALL BURRS AND SHARP EDGES. DO NOT SCALE THIS DRAWING.
TOLERANCES NOT SHOWN ABOVE ARE PER ANSI Y14.5-1973
THIS PRINT IS THE PROPERTY OF AUTO CRANE CO. AND MUST NOT BE USED IN ANY MANNER DETRIMENTAL TO THEIR INTERESTS.

AUTO CRANE
4707 NORTH MINGO ROAD
P.O. BOX 580697
TULSA, OKLAHOMA 74158-0697
918-836-0463

TITLE: **KIT, REINFORCEMENT, TITAN 38/84CA, RETROFIT**

DRAWN BY	DATE	SIZE	DRAWING NO.	REV
CDS	1/13/20	B	715068044	A

SCALE: DO NOT SCALE DRAWING WEIGHT: 34.26 LBS SHEET: 1 OF 1