

# TITAN 50-85 120CA BOOM SUPPORT REINFORCEMENT INSTALLATION

The Boom Support Reinforcement structure is installed in the Mid and Front Compartment of the Titan 38 84CA Body. Clean and remove paint and prepare area for welding of the parts on the top of the compartments. Remove any components that will be damaged during the welding process, bulk tanks, hydraulic hoses, wire harness and loom, cabinet lights, tool boxes.

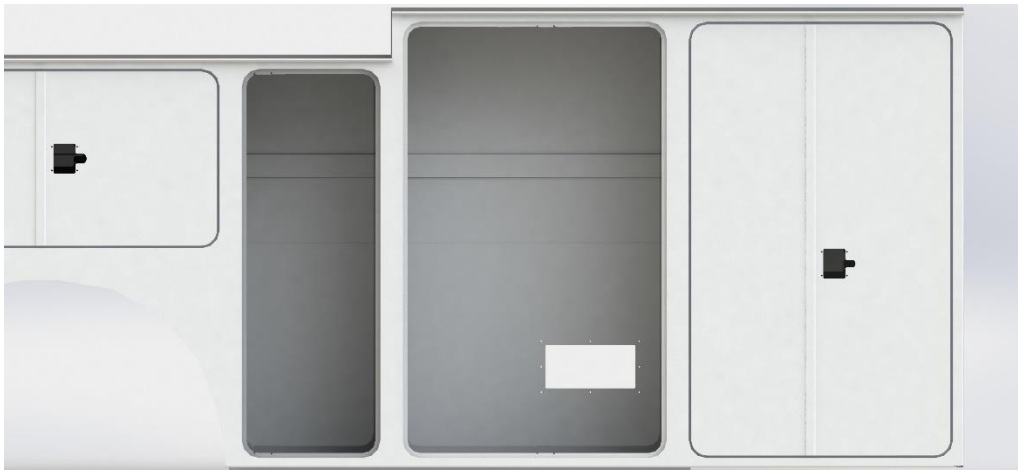

## Weld Instructions

1. Install the 715068034 plate as shown below. Locate plate on top of compartment and flush against front of compartment. Locate 1/8" against the 1 x 1 angle.

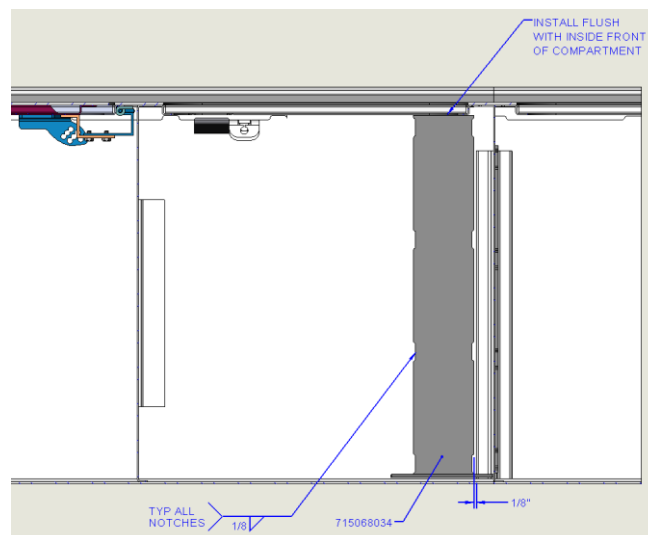

# TITAN 50-85 120CA BOOM SUPPORT REINFORCEMENT INSTALLATION

2. Install the 715068006 Plate as shown below in the back of the Mid compartment  
Located in the upper back corner of the compartment

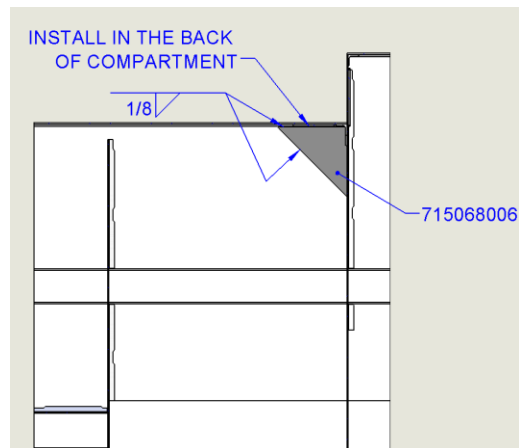

3. Install the 715068031 & 715068032 channels on the inside top of the Mid compartment as shown below

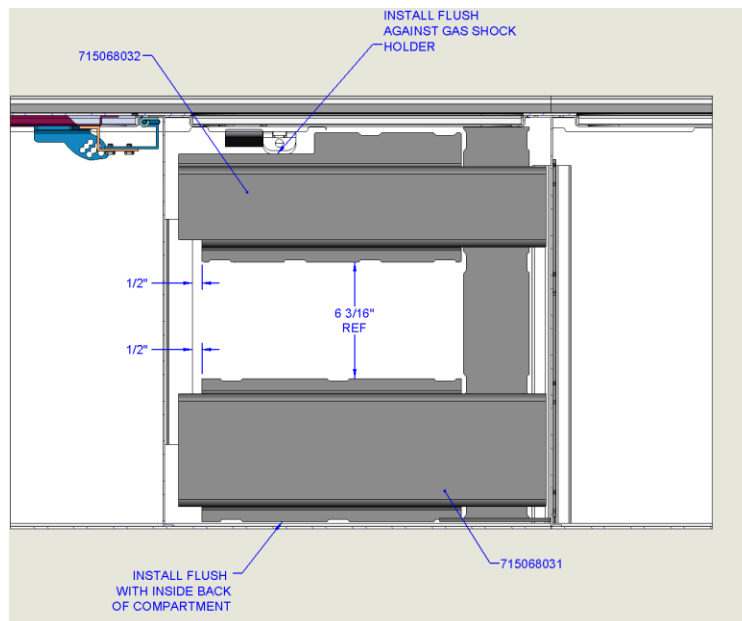

# TITAN 50-85 120CA BOOM SUPPORT REINFORCEMENT INSTALLATION

4. Locate the 715068033 plate inside the Second Front Compartment against the Mid/Front Divider wall and weld as shown below

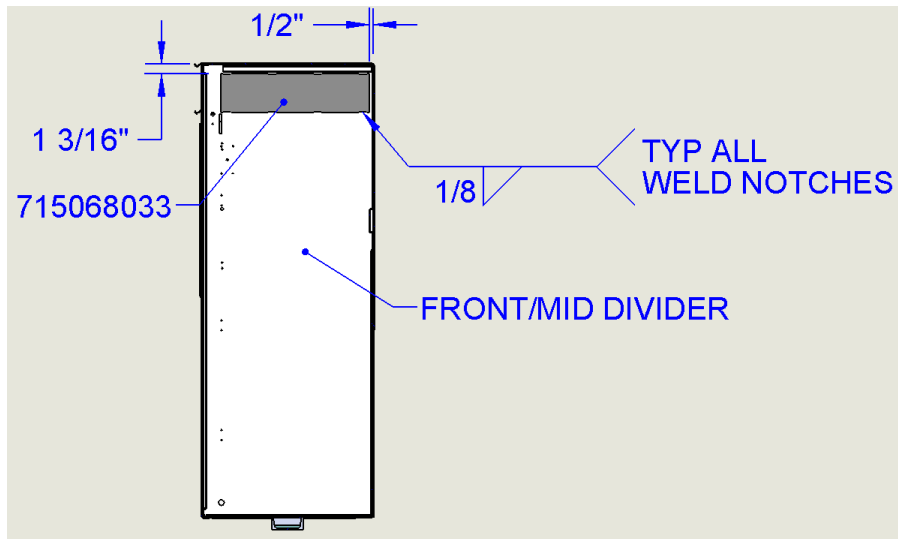

5. Weld Drip Rail on top to Face as shown below

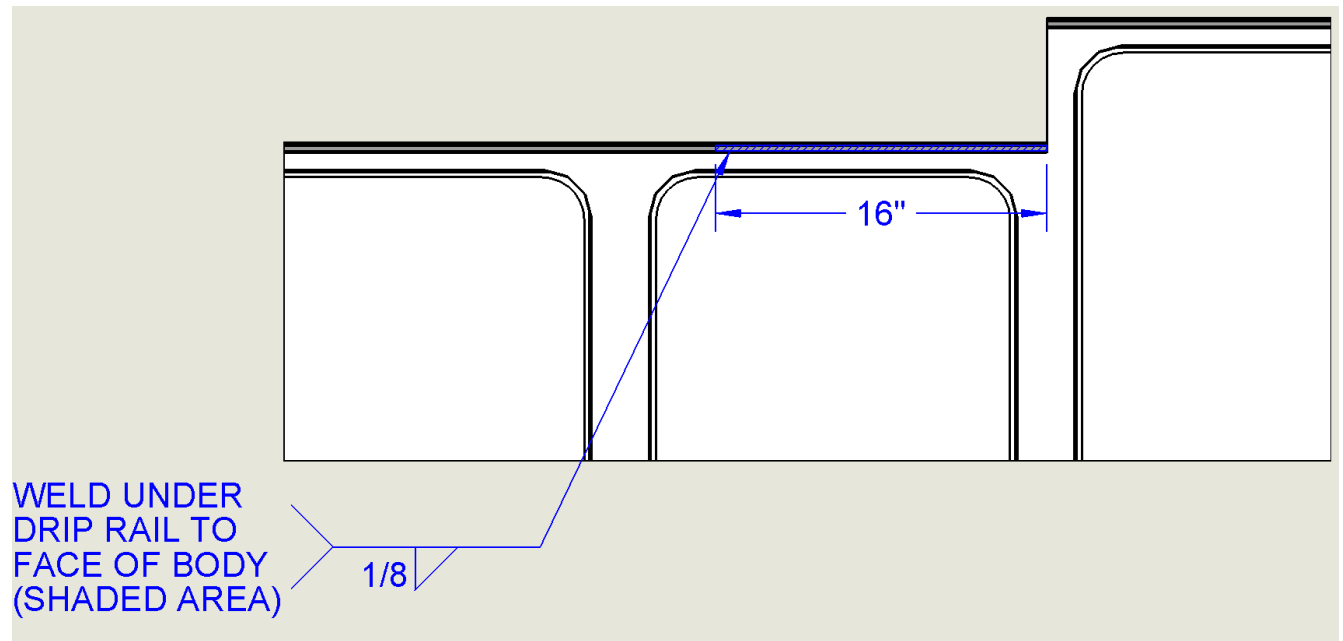

# **TITAN 50-85 120CA BOOM SUPPORT REINFORCEMENT INSTALLATION**

## **Installation Example Photos**

Typical 1/8" Fillet Weld on Components



Channel located Flush with Gas shock Holder

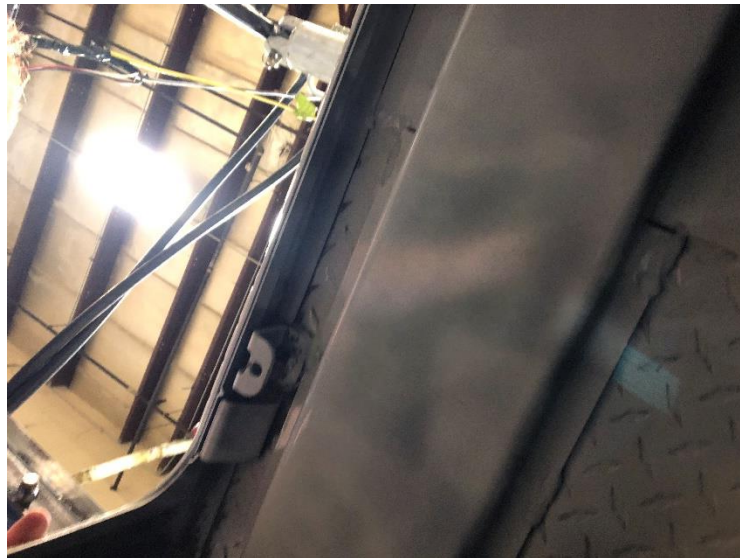

# **TITAN 50-85 120CA BOOM SUPPORT REINFORCEMENT INSTALLATION**

Typical Reinforcement Installation

