

TITAN 50-85 84CA BOOM SUPPORT REINFORCEMENT INSTALLATION

The Boom Support Reinforcement structure is installed in the Mid and Front Compartment of the Titan 38 84CA Body. Clean and remove paint and prepare area for welding of the parts on the top of the compartments. Remove any components that will be damaged during the welding process, bulk tanks, hydraulic hoses, wire harness and loom, cabinet lights, tool boxes



Weld Instructions

1. Install the 715068045 plate as shown below. Locate plate on top of compartment and flush against front of compartment. Locate 1-3/4" from the compartment divider.

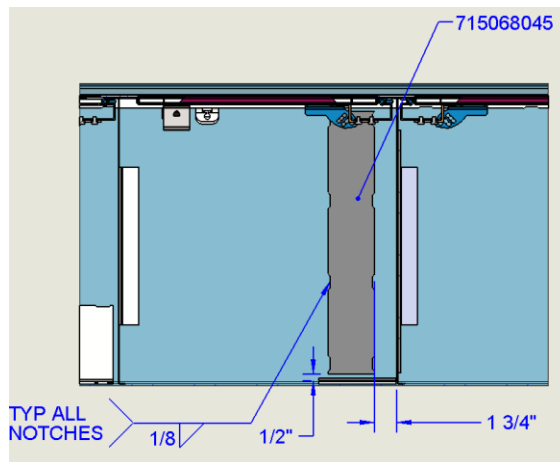

TITAN 50-85 84CA BOOM SUPPORT REINFORCEMENT INSTALLATION

2. Install the 715068006 Plate as shown below in the back of the Mid compartment
Located in the upper back corner of the compartment

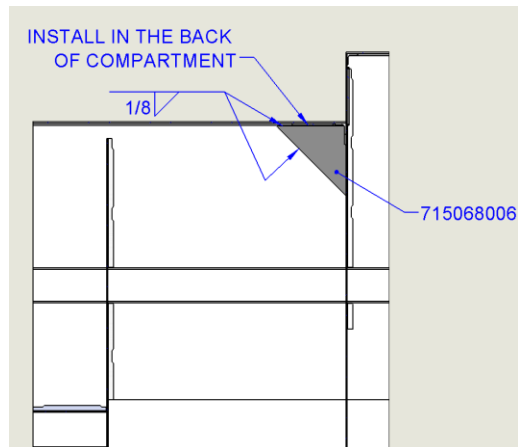

3. Install the 715068035 & 715068036 channels on the inside top of the Mid compartment as shown below

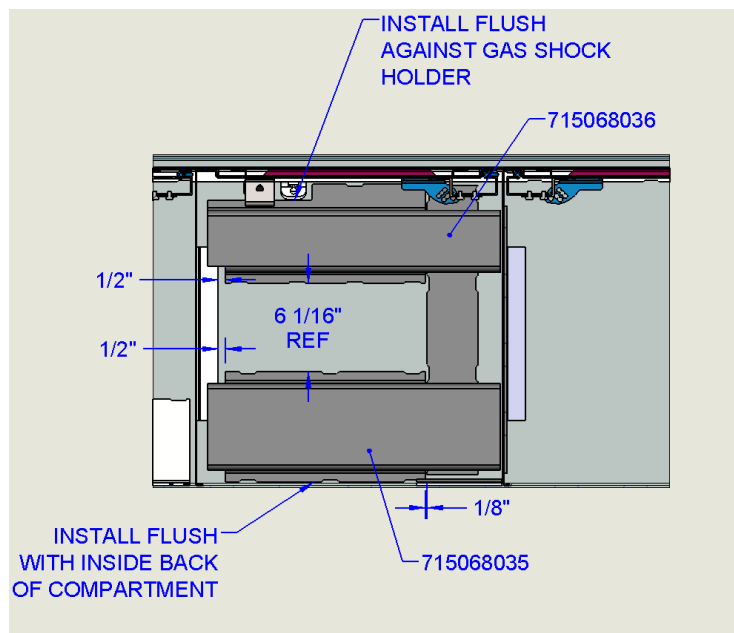

TITAN 50-85 84CA BOOM SUPPORT REINFORCEMENT INSTALLATION

4. Locate the 715068037 plate inside the Front Compartment against the Mid/Front Divider wall and weld as shown below

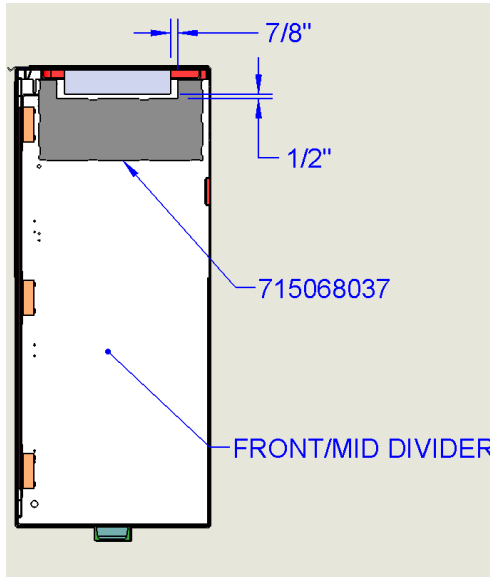

5. Weld Drip Rail on top to Face as shown below

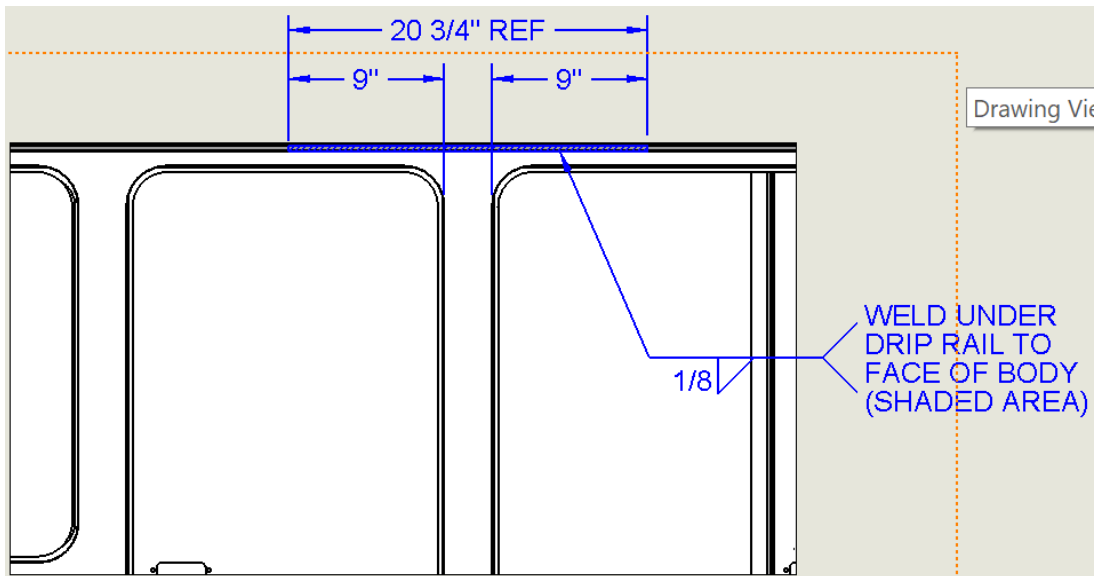

TITAN 50-85 84CA BOOM SUPPORT REINFORCEMENT INSTALLATION

Installation Example Photos

Typical 1/8" Fillet Weld on Components



Channel located Flush with Gas shock Holder

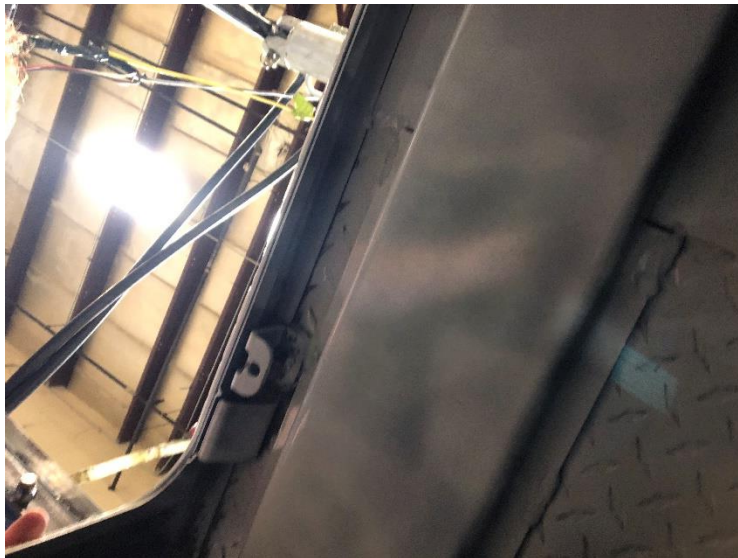

TITAN 50-85 84CA BOOM SUPPORT REINFORCEMENT INSTALLATION

Typical Reinforcement Installation

