

OWNERS MANUAL

Solid State Auxiliary Battery Switch

ABS-100 100 Amp

ABS-150 150 Amp

ABS-175 175 Amp

ABS-200 200 Amp

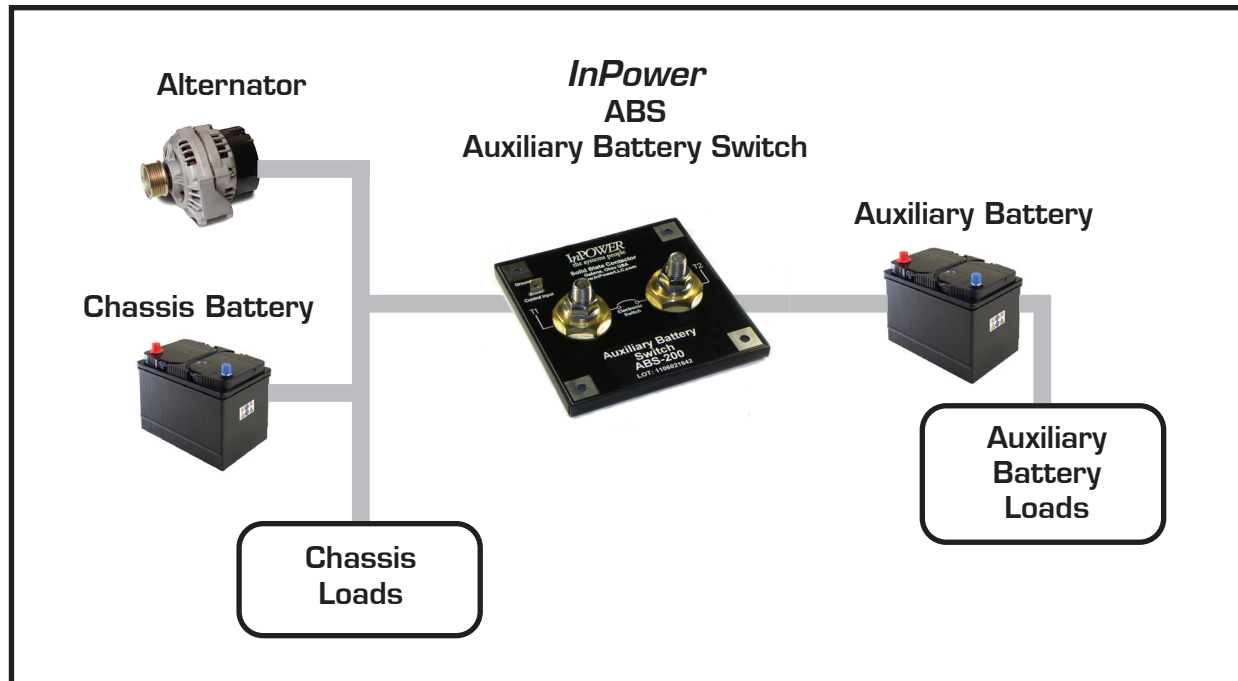

Introduction

InPower's ABS Series Auxiliary Battery Switch is the next generation technology for charging and isolating an auxiliary battery from a vehicle's chassis battery and alternator. The ABS auxiliary battery switch uses InPower's proven Patent-Pending solid-state contactor technology incorporating sophisticated microprocessor algorithms that include over-current, over temperature, and under-voltage sensing.

The basic operating principles are simple. The auxiliary battery is charged from the chassis battery and alternator while the chassis battery is protected from auxiliary battery load discharge. As the ABS is bidirectional, a charging device such as a battery charger or genset connected to the auxiliary battery can also supply charging current to the chassis battery. The ABS switch accomplishes this through the voltage and current monitoring capabilities of its microprocessor controller. The proper time to transfer power between the chassis battery and the auxiliary battery is based on a proprietary algorithm that utilizes both battery voltage and current measurements. A "boost start" feature is provided that will allow the auxiliary battery to supply current to the chassis battery to aid engine starting.

ABS auxiliary battery switches are available in 100, 150, 175 and 200 amp models. The required ABS current rating is determined by calculating the maximum alternator output current less the minimum chassis load current.

InPOWER
the systems people

© Copyright 2012 InPower LLC

InPower LLC
8311 Green Meadows Drive
Lewis Center, Ohio 43035 USA
740-548-0965
www.InPowerDirect.com

Page
1 of 6

ABS Owners Manual

Document: OM-141
Date: June 2, 2011

Version Code: B
Date: May 22, 2012

System Diagram

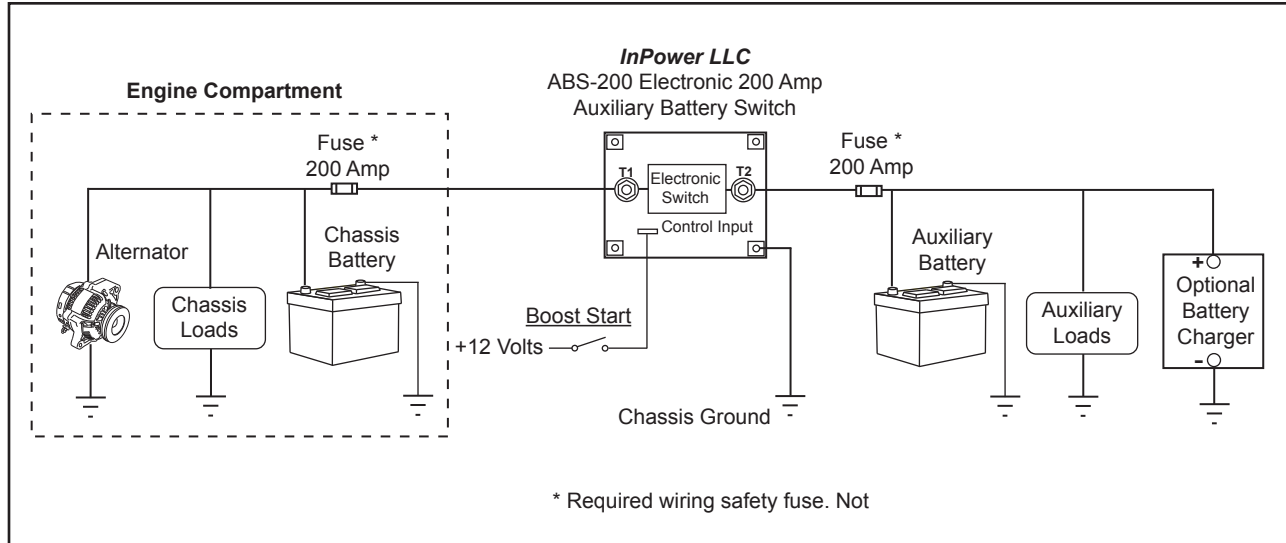

Figure 1

Operation

Normal Operation - Charging and isolating an auxiliary battery from the chassis battery and alternator.

1. The engine is running and the alternator starts supplying current to the chassis battery. When the chassis battery voltage rises above 13.5 volts for 20 seconds, and the auxiliary battery's voltage is above 3.0 volts, the InPower ABS switch will close, connecting the two batteries. The auxiliary battery will now recharge. Note that the ABS switch requires one battery to be above 7.5 volts and the other to be above 3.0 volts before it can close. This is to eliminate the possibility of a shorted or missing auxiliary battery. If the ABS rated current is exceeded for 500 milliseconds the ABS switch will turn off. It will automatically reset every 20 seconds.

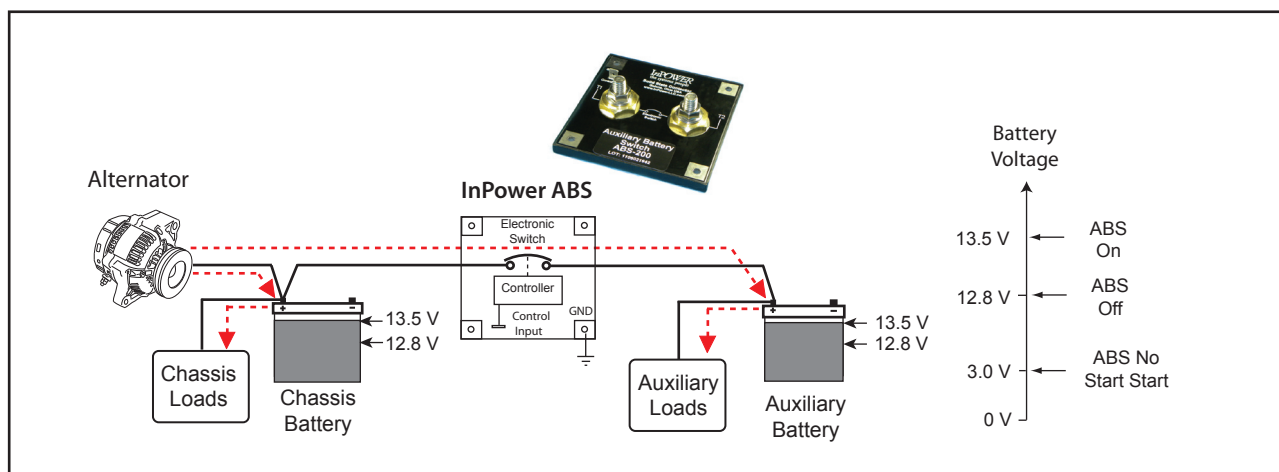

Figure 2

Operation, Continued

- If the engine is stopped, no alternator current is produced and the batteries begin to discharge. When the voltage of the combined batteries drops below 12.8 volts for 10 seconds the ABS switch will open, isolating the auxiliary battery from the chassis battery and alternator.

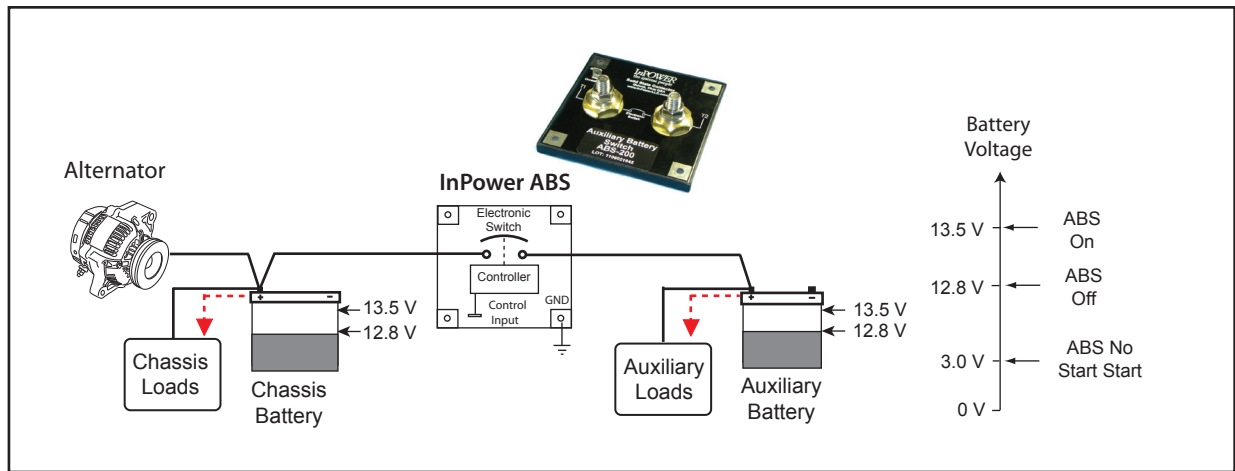

Figure 3

Boost Mode - Using the auxiliary battery to boost start

In the event the chassis battery is discharged the auxiliary battery may be used to supply current to the chassis battery to aid engine starting. The Boost Start control input to the ABS switch is activated from a remote momentary switch. The ABS switch closes to connect the auxiliary battery to the chassis battery for the duration that the boost start is applied. Note - Both batteries must be above 3.0 volts for this function to operate. If the ABS rated current is exceeded for 500 milliseconds the ABS switch will turn off. It will reset after removing the Boost Start control input and then reapplying it.

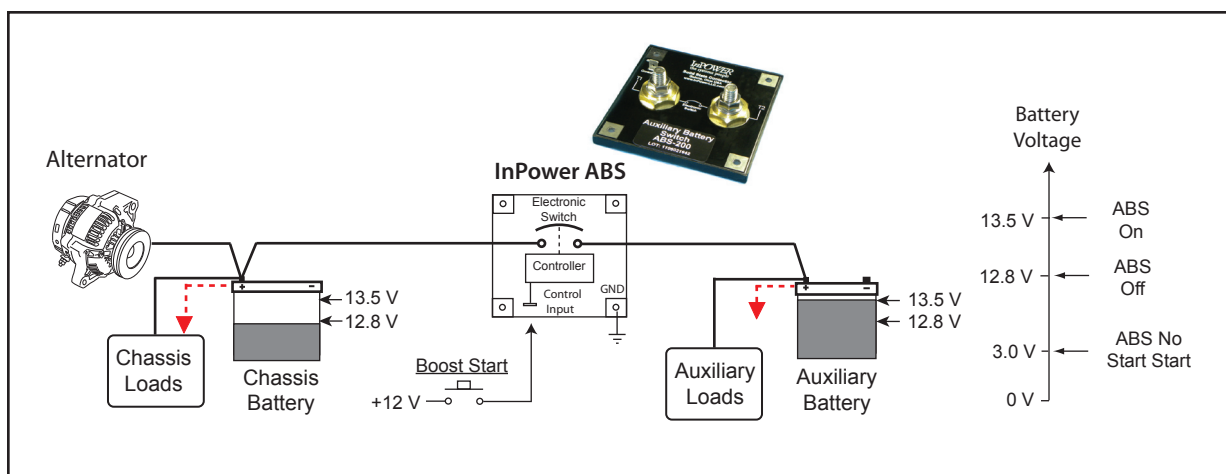

Figure 4

Installation Procedure



WARNING

Do not weld on the vehicle with the Auxiliary Battery Switch installed as damage to the product may result. If electric welding is necessary, disconnect the cables attached to the T1 and T2 terminals. Damage due to electric welding while the unit is installed will void InPower's warranty.

Introduction

This manual provides instructions for installing the InPower Auxiliary Battery Switch (ABS). It is important that you follow these instructions carefully and contact InPower if you need assistance or more information. You can reach InPower at:

InPower LLC
Customer Support
Tel: 740-548-0965
Toll Free: 866-548-0965
Web Site: www.InPowerDirect.com

Safety Precautions

This product requires the installer to be trained for installation and work on vehicle electrical systems. We recommend that all wiring meet the SAE and applicable vehicle manufacturer's wiring specifications. Inspect the product and all other components for damage before starting the installation. Do not perform the installation if any problems exist.

Wear appropriate safety equipment such as eyeglasses, face shield and clothing when installing the equipment and handling the battery. Be careful when working near a battery. Make sure the area is well ventilated and that there are no flames near the battery. Never lay objects on the battery that can short the terminals together or to ground. If battery acid gets in your eyes immediately seek first aid. If acid gets on your skin immediately wash it off with soap and water.

Mounting Location

- First determine where the module will be mounted.
- The ABS, although sealed, must be mounted in a protected and dry area.
- The ABS is not designed for exposure to saltwater spray, environmental debris or power washing.
- It must be mounted to a flat metal surface that maintains ambient temperature.
- **The module must not be mounted in the engine compartment or any location near the engine's heat.**
- Take into consideration the routing of the two battery cables.
- Connect only the battery cables to the ABS power terminals. Do not use these terminals for a junction post.
- For maximum thermal efficiency the mounting surface should be a thick metal surface such as an aluminum plate 1/8 x 12 x 12 inches or larger.
- To facilitate heat transfer a square piece of thermal transfer material is supplied with each ABS.
 1. Remove the clear plastic protective coating and insert the heat transfer material between the module and the mounting surface.
 2. Secure the module to the flat metal surface using four #6 or #8 screws and tighten to a torque setting of 5 inch pounds. **Do not drill out the contactor's four mounting pad holes to use a larger bolt size. Drilling the mounting holes out will damage the unit and void the warranty.**

Grounding

Proper operation of the ABS is dependent on a good quality ground system. Both the chassis battery and

Installation Procedure, Continued

the auxiliary battery must be connected to a solid common ground. The ABS must be connected to this common ground. **Do not drill out the contactor's four mounting pad holes to use a larger bolt size. Drilling the mounting holes out will void the warranty.** Install a #16 AWG ground wire with a ring terminal under one of the four ABS mounting screws and connect it to the common battery ground. Note that the best ground is at the chassis battery's negative terminal.

Battery Cable Fusing for Wiring Protection

A fuse must be installed in each cable connecting the ABS switch to the chassis and auxiliary batteries (Refer to Figure 1). Each fuse must be located within 16 inches of the respective battery. Refer to Table A for the minimum fuse size for each ABS switch model.

Table A
Safety Fuse Size

ABS Mode	Minimum Fuse Size
ABS-100	125 amps
ABS-150	175 amps
ABS-175	200 amps
ABS-200	225 amps

Note - Fuses, fuse holder and terminal insulating boots are available from InPower.

Connect the Power Cables

Prepare the two cables to the batteries using a suitable size cable for the current required and install a crimped lug terminal on the end. Install a fuse in each battery cable. The fuse rating must match the ABS rated current capacity. Install the fuses within 16 inches of the battery. Terminal T1 is connected to the positive terminal of the chassis battery and terminal T2 is connected to the positive terminal of the auxiliary battery. It is good engineering practice to use protective boots over terminals T1 and T2. Install the boots over the cables and lugs, then install the cables as shown in the Figure 5 diagram. **Torque the nut to the torque specification shown in the Figure 5 diagram.** The terminals may then be coated with a standard battery terminal protective sealant. Slide the boots over the lugs and onto the power terminals.

Installation Diagram

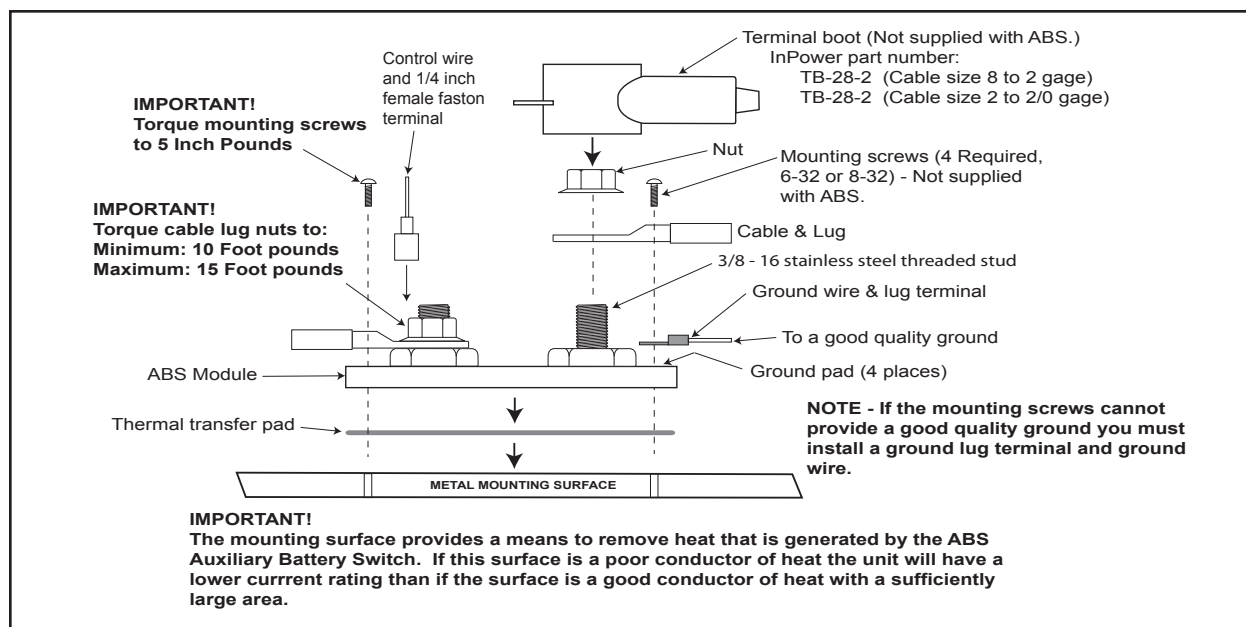

Figure 5

Fuse Installation Diagram

Fuses and fuse holders not supplied with ABS and must be ordered separately.

Fuse Holder InPower model # FH-01

Fuses (Mega type):

125 amp InPower model # FM-125

175 amp InPower model # FM-175

200 amp InPower model # FM-200

225 amp InPower model # FM-225

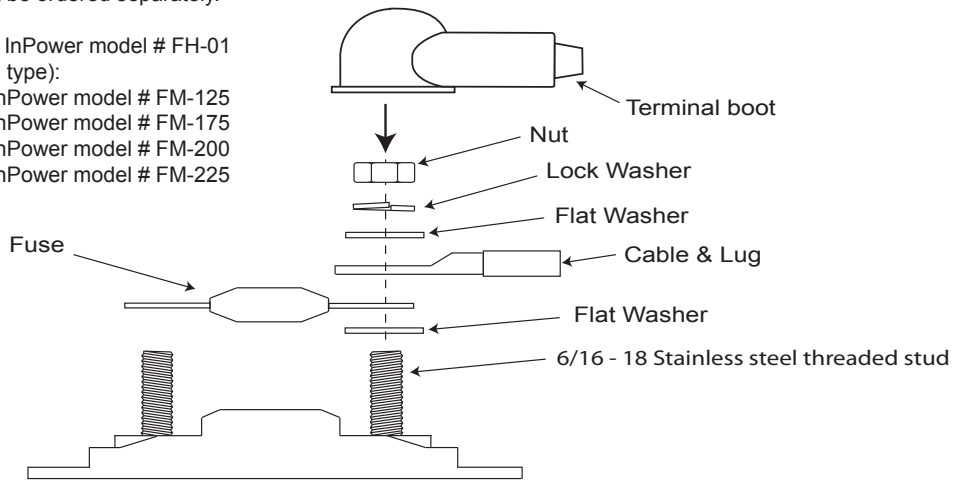

Figure 6

Mechanical Diagram

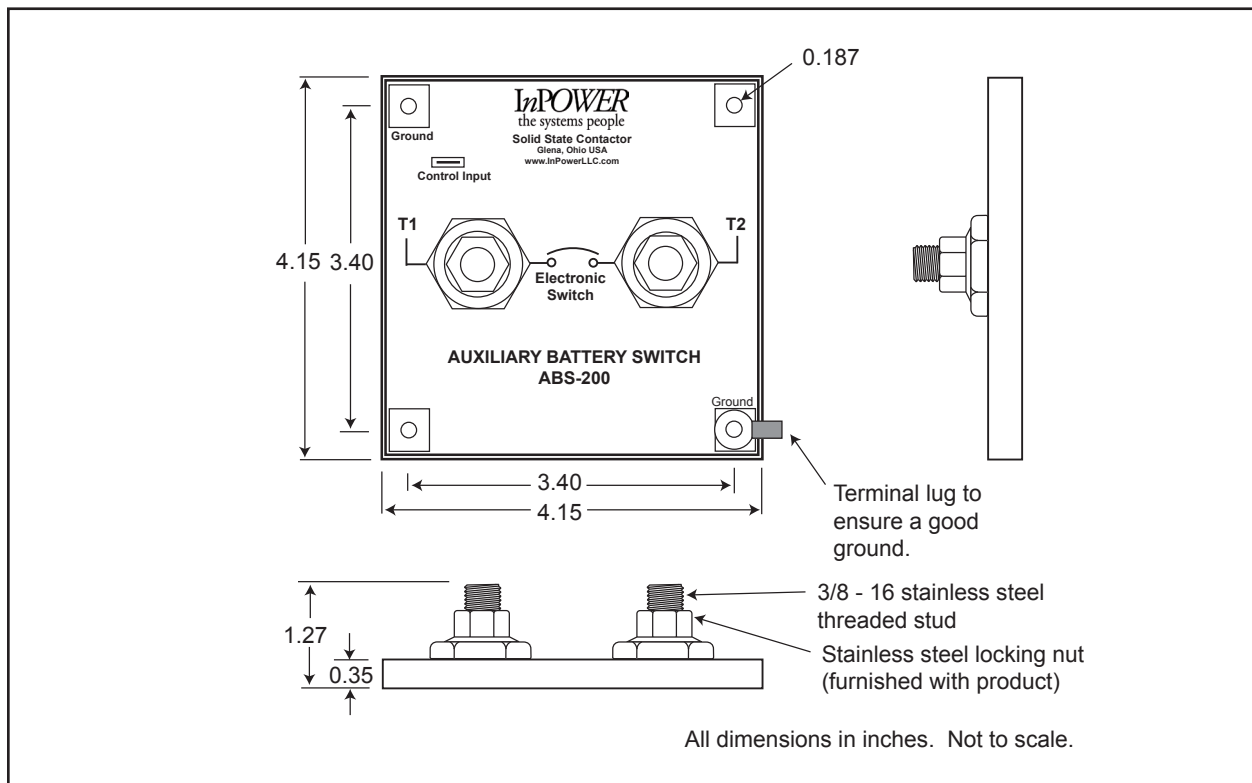

Figure 7